

RT5394

ROUGH TERRAIN SERIES

SCISSOR LIFT



KEY SPECS

Platform Height
53-ft / 16.2-m

Platform Capacity
1,500-lb / 680-kg

Machine Width
7-ft 7-in / 2.3-m

Stowed Drive Speed
3.5 mph / 5.6 km/h

KEY FEATURES

- Enhanced stability on uneven surfaces with a standard oscillating axle for better traction and grade climbing ability.
- With the operator in mind, the platform is designed to shed debris and to allow for smoother extension deployment.
- The fully accessible hydraulic and engine compartments provide for enhanced ease of service.
- A standard 4-ft deck extension provides more space for people and materials.

ACCESSORIES & OPTIONS

- 1/2-in Airline to Platform
- 43.5-lb (19.7-kg) Propane Tank
- Cold Weather Start Kit
- Dual Extension Deck
- Flashing Amber Beacon
- Large Material Rack
- Pipe Rack Accessory
- Platform Worklights
- SkyPower®
- SkyPower with SkyWelder
- Workstation

STANDARD SPECIFICATIONS

Performance

Platform Height (Elevated)	53-ft / 16.2-m
Platform Capacity	1,500-lb / 680-kg
Capacity on Platform Extension	500-lb / 227-kg
Number of Occupants	6
Lift / Lower Time	65/60 seconds
Maximum Drive Height	32-ft / 9.75-m
Weight w/One Extension*	17,110-lb / 7,761-kg
Ground Bearing Pressure	90 psi / 6.3 kg/cm ²
Drive Speed (Lowered)	3.5 mph / 5.6 km/h
Drive Speed (Elevated)	.5 mph / .8 km/h
Gradeability	40%
Max Tilt Rating (Side-to-Side)	1.5 Degrees
Max Tilt Rating (Fore and Aft)	1.5 Degrees
Turning Radius (Inside)	9-ft / 2.7-m
Turning Radius (Outside)	19-ft 9-in / 6.0-m

*Certain options or country standards increase weight

Engine

Dual Fuel – Kubota W6972	31 hp / 23 kW
Diesel Fuel – Kubota D1305	24.8 hp / 18.5 kW
Fuel Tank Capacity	22 gal / 83.3 L

Tires

Standard	12 x 16.5-in Foam-filled
----------	--------------------------

Brakes

Four Wheel	Spring Applied
------------	----------------

Hydraulic System

Capacity	32 gal / 121.4 L
----------	------------------

STANDARD FEATURES

- 110V-AC Receptacle in Platform
- 4-ft (1.22-m) Manual Deck Extension
- 4-Wheel Drive
- 70.5 x 149.8-in (1.8 x 3.8-m), All Steel Platform with Aluminum Deck
- Adjustable, Removable Platform Control Station
- All Motion Alarm
- Automatic Transmission
- Fold-Down Handrails
- Horn
- Leveling Jacks
- Oscillating Axle
- Proportional Drive/Lift Up/Lift Down
- Self-Closing Gate
- Three-speed Drive Select
- Tilt Light and Alarm

RT5394

ROUGH TERRAIN SERIES

SCISSOR LIFT



DIMENSIONS

All dimensions are approximate

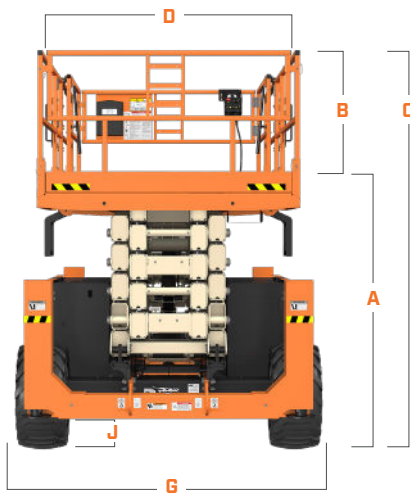

- A.** Platform Height (Rails Lowered) 7-ft 9-in / 2.36-m
- B.** Platform Railing Height 43.5-in / 1.1-m
- C.** Machine Height 10-ft 5-in / 3.2-m
- D.** Platform Width 70.5-in / 1.8-m
- E.** Platform Length 149.8-in / 3.8-m

- F.** Platform Extension 4-ft / 1.2-m
- G.** Machine Width 7-ft 7-in / 2.3-m
- H.** Machine Length 16-ft / 4.9-m
- I.** Wheelbase 9-ft 9-in / 3.0-m
- J.** Ground Clearance 12-in / 30-cm



We provide coverage for one (1) full year, and cover all specified major structural components for five (5) years. Due to continuous product improvements, we reserve the right to make specification and/or equipment changes without prior notification. This machine meets or exceeds applicable ANSI and CSA requirements based on machine configuration as originally manufactured for intended applications. Please reference the serial number plate on the machine for additional information.



JLG INDUSTRIES, INC.
Toll-free US 877-JLG-LIFT
JLG.com

An Oshkosh Corporation Company