

ES4046

ELECTRIC SCISSOR LIFT

SCISSOR LIFT



KEY SPECS

Platform Height

Indoor: 39.1-ft / 11.9-m
Outdoor: 28-ft 8.5-in / 8.75-m

Platform Capacity

Indoor: 770-lb / 349-kg
Outdoor: 550-lb / 250-kg

Number of Occupants

Indoor: 3
Outdoor: 1

Stowed Drive Speed

3 mph / 4.8 km/h

KEY FEATURES

- Enhance productivity with more than a 40% increase in duty cycles over its hydraulic drive predecessor and an indoor capacity of three occupants.
- Reduce operating costs with electric drive and integrated components containing reduced hydraulic hoses and hydraulic fittings on the entire machine.
- Work in sensitive areas with optional CleanGuard leak containment system.
- Features a standard USB charger and phone holster, improving the operator experience while delivering a high degree of commonality with other JLG® scissors to simplify service.

ACCESSORIES & OPTIONS

- 4 x 6V AGM Batteries, 260 ah
- 900W Inverter
- Anti-Vandalism Package
- CleanGuard® Leak Containment System
- Coiled Platform Control Box Cable
- Drive Motor Covers
- Dual Flashing Amber Beacons - LED
- MDI (Ground)
- Panel Carrier
- Pipe Racks
- SkySense® Enhanced Detection System
- White Noise Alarm

STANDARD SPECIFICATIONS

Performance	Indoor	Outdoor
Platform Height (Elevated)	39.1-ft / 11.9-m	28-ft 8.5-in / 8.75-m
Platform Capacity	770-lb / 350-kg	550-lb / 250-kg
Capacity on Platform Extension	250-lb / 113-kg	250-lb / 113-kg
Number of Occupants	3	1
Lift / Lower Time (No Load)	66/52 Seconds	66/52 Seconds
Lift / Lower Time (Rated Load)	76/42 Seconds	76/42 Seconds
Maximum Drive Height	39.1-ft / 11.9-m	28-ft 8.5-in / 8.75-m
Weight*	6,230-lb / 2826-kg	6,230-lb / 2826-kg
Max. Ground Bearing Pressure	152psi/ 10.7 kg/cm ²	152psi/ 10.7 kg/cm ²
Drive Speed (Lowered)	3 mph / 4.8 kmh	3 mph / 4.8 kmh
Drive Speed (Raised)	0.5 mph / 0.8 km/h	0.5 mph / 0.8 km/h
Gradeability	25%	25%
Max Tilt Rating (Side-to-Side)	1.50 Degrees	1.50 Degrees
Max Tilt Rating (Fore and Aft)	3.50 Degrees	3.50 Degrees
Turning Radius (Inside)	Zero	Zero
Turning Radius (Outside)	94.4-in / 2.39-m	94.4-in / 2.39-m

*Certain options or country standards increase weight

Power

Batteries	4 x 6V 255 AH
Charger	27 Amp
Drive	24V DC

Tires

Standard	16 x 5-in / 406 x 125-mm
----------	--------------------------

Brakes

Multi-Disc Friction

Hydraulic System

Capacity	3.2 gal / 12 L
Pump	Fixed Displacement Gear

STANDARD FEATURES

- 27 amp Multi-Function Universal Charger
- Active Pothole Protection System
- All Motion Alarm
- Analyzer Port for Diagnostics
- Battery Condition Indicator
- CAN-Enabled Charger
- ClearSky Smart Fleet™ Hardware (CS550)
- Diamond Tread Steel Deck
- Dynamic Braking
- Electric Drive
- Foot-Actuated Deck Extension
- Fork Lift Pockets
- Greaseless Kingpin Joints
- Horn
- Hourmeter
- Lanyard Attach Points
- Lifting and Tie Down Points
- LED Motion/Amber Beacon (CS550)
- Load Sensing System
- Lubrication Free Scissor Arm Bushings
- Manual Descent Cable
- Movable, Removable Platform Control
- Proportional Controls
- Fold Down Rails
- Removable Ladder
- Scissor Maintenance Prop
- Self-Closing Gate
- Steel Swing-Out Doors
- Tilt Alarm and Light
- USB Charger & Phone Holster
- Variable Tilt Visual Zone Indicator

ES4046

ELECTRIC SCISSOR LIFT

SCISSOR LIFT



DIMENSIONS

All dimensions are approximate

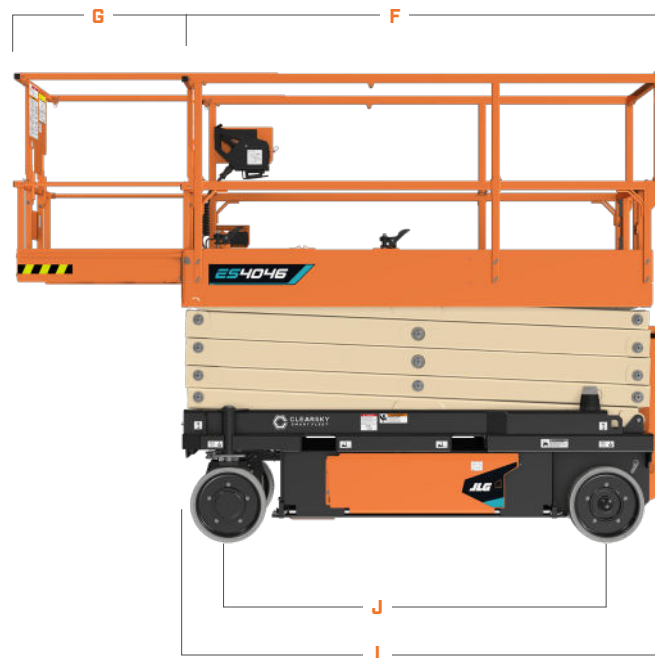
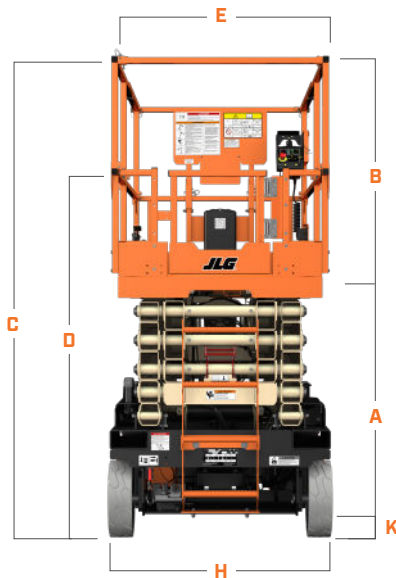

A. Platform Height (Lowered)	54.8-in / 1.4-m	H. Machine Width	46-in / 117-cm
B. Platform Railing Height	44.6-in / 1.13-m	I. Machine Length	106.6-in / 2.7-m
C. Machine Height (Rails Raised)	99.5-in / 2.53-m	J. Wheelbase	80.6-in / 2.04-m
D. Machine Height (Rails Lowered)	78.2-in / 1.99-m	K. Ground Clearance	4.9-in / 12.45-cm
E. Platform Width	37.6-in / 95.5-cm		
F. Platform Length	97.9-in / 2.47-m		
G. Platform Extension	35.9-in / 91.2-cm		



We provide coverage for one (1) full year, and cover all specified major structural components for five (5) years. Due to continuous product improvements, we reserve the right to make specification and/or equipment changes without prior notification. This machine meets or exceeds applicable ANSI and CSA requirements based on machine configuration as originally manufactured for intended applications. Please reference the serial number plate on the machine for additional information.



JLG INDUSTRIES, INC.
Toll-free US 877-JLG-LIFT
JLG.com

An Oshkosh Corporation Company