

X600AJ

COMPACT CRAWLER

BOOM LIFT



STANDARD SPECIFICATIONS

Performance

Platform Height	59-ft 3-in / 18.05-m
Horizontal Outreach	30-ft / 9.1-m
Platform Capacity	500-lb / 227-kg
Swing	360 Degrees Non-continuous
Platform Rotation	124 Degrees (+62, -62 Degrees)
Jib (Range of Articulation)	89 Degrees (0, -89 Degrees)
Ground Bearing Pressure (Tracks)	9.28 psi / .66 kg/cm ²
Ground Bearing Pressure (Outriggers)	44.09 psi / 3.09 kg/cm ²
Max Approach / Depart Angles	20° / 21°
Drive Speed	0.8 mph / 1.3 km/h
Gradeability	28%
Weight* (Diesel)	6,571-lb / 2,980-kg

*Certain options or country standards increase weight

Power

Diesel Engine: Kubota Z602	19.5 hp / 14.5 kW
Fuel Tank Capacity	1.5 gal / 5.9 L
AC Motor	120V AC / 60 HZ
Optional: 72V Lithium-Ion Battery	72V / 100Ah

Tracks

Standard	Non-marking Tracks
----------	--------------------

Hydraulic System

Capacity	10.56 gal / 40 L
----------	------------------

KEY SPECS

Platform Height 59-ft 3-in / 18.05-m	Platform Capacity 500-lb / 227-kg
Horizontal Outreach 30-ft / 9.1-m	Overall Width 31-in / 0.78-m

KEY FEATURES

- Best-in-class 500-lb unrestricted platform capacity.
- Environmentally friendly with standard AC powered boom functions, diesel or an optional lithium-ion electrical system for emission-free operation.
- Access tight spaces and climb slopes with ease thanks to a narrow chassis and tracked wheel carriage.
- Transport with ease by a forklift or crane with forklift pockets and lifting eyes, and fits through standard doorway.

ACCESSORIES & OPTIONS

- Black Deep-Tread Tracks
- Platform, Single-Person 31 x 24-in

STANDARD FEATURES

- 110V AC Receptacle in Platform
- 360 Degree Non-Continuous Swing
- 58 x 30-in Removable Aluminum Platform, Dual Side Entry
- 5-ft Articulating Jib
- AC Motor for Indoor Operation
- Air/Water Line to Platform
- Electronic Controls with One-Touch Outrigger Deployment
- Emergency Lowering Pump
- Flashing Amber Beacon
- Fork Lift Pockets
- Lifting Eyes
- Load Sensing System
- Non-Marking Tracks
- Powered Track Widening
- Proportional Controls
- Removable Controller
- SkyGuard SkyLine™
- Synthetic Biodegradable Hydraulic Oil
- Telematics-Ready Harness
- Tie Down Lugs

X600AJ

COMPACT CRAWLER

BOOM LIFT



DIMENSIONS

All dimensions are approximate

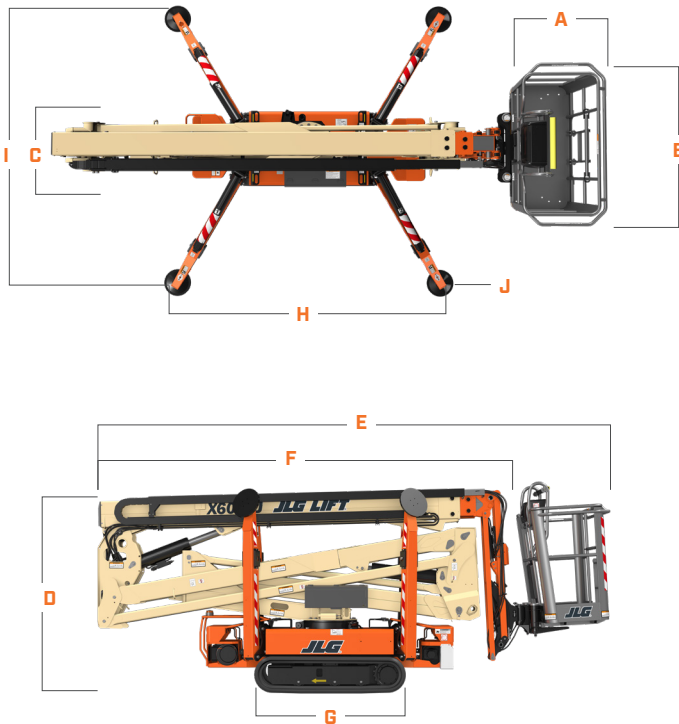

A. Platform Width	30-in / 76-cm
B. Platform Length	58-in / 1.47-m
C. Machine Width*	31-in / 78-cm
D. Machine Height	6-ft 6-in / 1.98-m
E. Machine Length	16-ft 5-in / 5.01-m
F. Machine Length Without Platform	15-ft 3-in / 4.65-m
G. Track length	4-ft 10-in / 1.47-m
H. Outrigger Footprint - Length	10-ft 7-in / 3.22-m
I. Outrigger Footprint - Width	10-ft 7-in / 3.23-m
J. Outrigger Pad Diameter	11.8-in / 30-cm

*Overall Width (with platform removed - tracks retracted)

REACH DIAGRAM

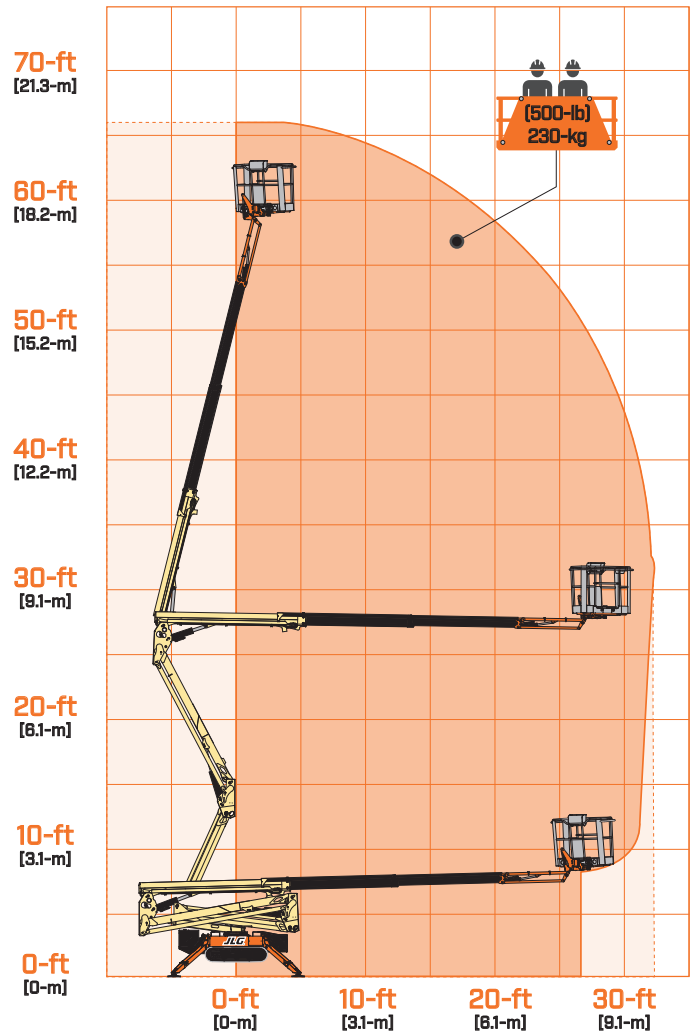

We provide coverage for one (1) full year, and cover all specified major structural components for five (5) years. Due to continuous product improvements, we reserve the right to make specification and/or equipment changes without prior notification. This machine meets or exceeds applicable ANSI and CSA requirements based on machine configuration as originally manufactured for intended applications. Please reference the serial number plate on the machine for additional information.



JLG INDUSTRIES, INC.
Toll-free US 877-JLG-LIFT
JLG.com

An Oshkosh Corporation Company