

E400AJPN

ELECTRIC BOOM

BOOM LIFT



KEY SPECS

Platform Height
40-ft / 12.19-m

Up and Over Reach
21-ft 6-in / 6.55-m

Horizontal Outreach
22-ft 5-in / 6.83-m

Platform Capacity
500-lb / 227-kg

KEY FEATURES

- Achieve maximum maneuverability by moving over uneven surfaces with Automatic Traction Control.
- Achieve optimum productivity with longer duty cycles.
- Produces zero emissions, 100% environmentally friendly.
- Also available as E400AN model.

ACCESSORIES & OPTIONS

- 1/2-in Airline to Platform
- Batteries, AGM
- Ambient White Noise Alarm
- Batteries, AGM
- Inverter - 1200W¹
- Inward Self-closing Swing Gate
- Light Package²
- Platform Mesh to Mid or Top Rail³
 - Aluminum or Plastic
- Platforms
 - Drop Bar, 30 x 36-in, 30 x 48-in
 - Inward Self-Closing Swing Gate, 30 x 48-in
- Inward Self-Closing Swing Gate with Stop, 30 x 60-in
- Storage Tray - Center
- UL EE Rating

STANDARD SPECIFICATIONS

Performance

Platform Height	40-ft / 12.19-m
Horizontal Outreach	22-ft 5-in / 6.83-m
Up and Over Clearance	21-ft 6-in / 6.55-m
Swing	360 Degrees Non-Continuous
Platform Capacity	500-lb / 227-kg
Platform Rotator	180 Degrees Hydraulic
Jib Length (Range of Articulation)	144 Degrees (+84, -60) Vertical
Weight*	14,900-lb / 6,759-kg
Ground Bearing Pressure	185 psi / 13 kg/cm ²
Max Drive Speed	4.2 mph / 6.7 km/h
Gradeability	30%
Turning Radius Inside (2WS/4WS)	2-ft 10-in / .86-m
Turning Radius Outside (2WS/4WS)	10-ft 4-in / 3.15-m

Power Source

Electrical System	48V DC
Batteries	8 x 6V, 312 amp-hr
Drive Motors	Dual Electric Traction

Tires

Standard (Front)	22 x 6 x 17.5-in Solid Non-marking
(Rear)	25 x 7 x 12-in Solid Non-marking

Hydraulic System

Capacity	4 gal / 15.14 L
Motor/Pump	Permanent Magnet Motor/Gear Pump

STANDARD FEATURES

- 110V-AC Receptacle in the Platform
- 12V DC Auxilliary Power
- 180 Degree Hydraulic Platform Rotator
- 3 Degree Tilt Cut-out
- All Motion Alarm
- Automatic Traction Control (ATC)
- Battery Condition Indicator
- Brushless AC Motors
- ClearSky Smart Fleet™ Hardware (CS550)**
- Horn
- Hourmeter
- LED Motion/Amber Beacon (CS550)**
- Lifting/Tie Down Lugs
- Load Sensing System
- Platform Console Machine Status Light Panel***
- SkyGuard SkyLine™
- Tilt Light and Alarm

*Certain options or country standards increase weight.

**Standard beacon and ClearSky Smart Fleet hardware availability varies by model throughout 2023.

***Provides indicator lights at platform control console for system distress, low fuel, degree tilt light and foot switch status.

1. Not Available On UL EE Rating.

2. Includes Platform Lights, Head and Tail Lights.

3. Not Available for 30 x 60-in Platform.

E400AJPN

ELECTRIC BOOM

BOOM LIFT



DIMENSIONS

All dimensions are approximate

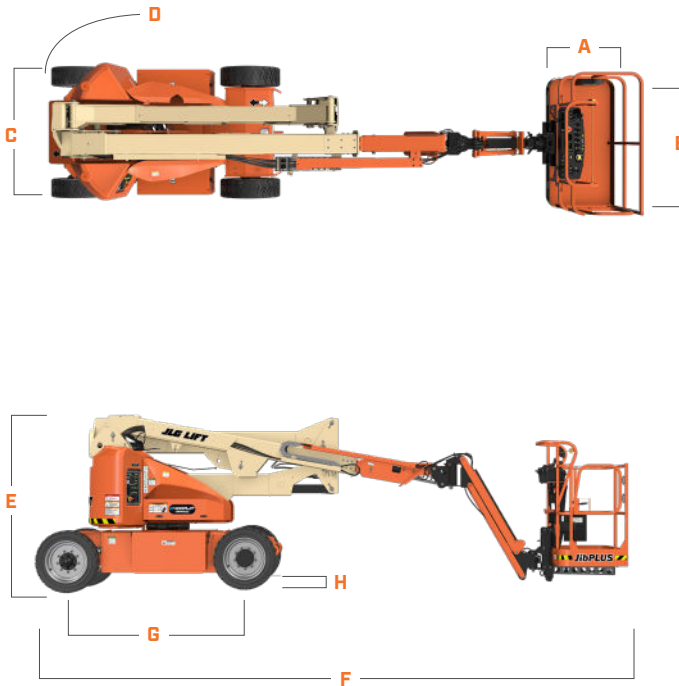

A. Platform Width	30-in / 76-cm
B. Platform Length	48-in / 1.22-m
C. Machine Width	4-ft 11-in / 1.5-m
D. Tailswing	4-in / 10-cm
E. Machine Height	6-ft 5.75-in / 1.97-m
F. Machine Length	22-ft / 6.71-m
G. Wheelbase	6-ft 7-in / 2.01-m
H. Ground Clearance	5-in / 13-cm

REACH DIAGRAM

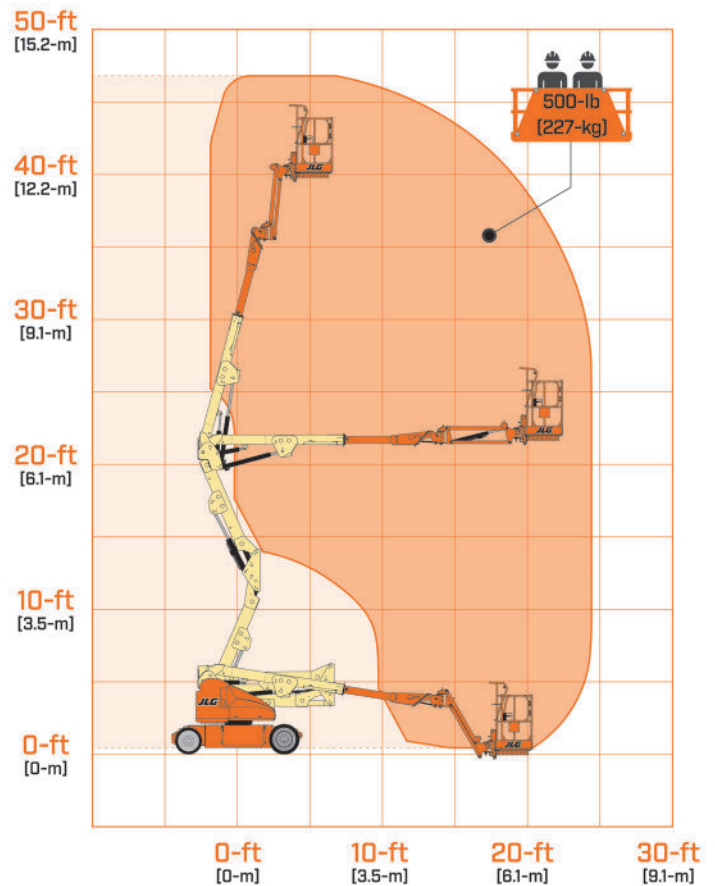

We provide coverage for one (1) full year, and cover all specified major structural components for five (5) years. Due to continuous product improvements, we reserve the right to make specification and/or equipment changes without prior notification. This machine meets or exceeds applicable ANSI and CSA requirements based on machine configuration as originally manufactured for intended applications. Please reference the serial number plate on the machine for additional information.



JLG INDUSTRIES, INC.
Toll-free US 877-JLG-LIFT
JLG.com

An Oshkosh Corporation Company