



Operation & Safety Manual

*Original Instructions -
Keep this manual with the machine at all times.*

***Model
1500SJ***

PVC 2307

31222387

July 10, 2023 - Rev A

ANSI CE UK CA 
AS/NZS GB MOL 70

JLG
An Oshkosh Corporation Company

WARNING

Operating, servicing and maintaining this vehicle or equipment can expose you to chemicals including engine exhaust, carbon monoxide, phthalates, and lead, which are known to the State of California to cause cancer and birth defects or other reproductive harm. To minimize exposure, avoid breathing exhaust, do not idle the engine except as necessary, service your vehicle or equipment in a well-ventilated area and wear gloves or wash your hands frequently when servicing. For more information go to www.P65Warnings.ca.gov.

FOREWORD

The Mobile Elevating Work Platform (MEWP) models covered in this manual are designed and tested to meet or exceed various compliance standards. Please refer to the manufacturer's nameplate affixed to the subject MEWP for specific standard compliance information.

This manual is a very important tool! Keep it with the machine at all times.

The purpose of this manual is to provide owners, users, operators, lessors, and lessees with the precautions and operating procedures essential for the safe and proper machine operation for its intended purpose.

Due to continuous product improvements, JLG Industries, Inc. reserves the right to make specification changes without prior notification. Contact JLG Industries, Inc. for updated information.

Refer to www.JLG.com for Warranty, Product Registration, and other machine-related documentation.

SAFETY ALERT SYMBOLS AND SAFETY SIGNAL WORDS



This is the Safety Alert Symbol. It is used to alert you to the potential personal injury hazards. Obey all safety messages that follow this symbol to avoid possible injury or death.

⚠ DANGER

Indicates an imminently hazardous situation. If not avoided, will result in serious injury or death. This decal will have a red background.

⚠ WARNING

Indicates a potentially hazardous situation. If not avoided, could result in serious injury or death. This decal will have an orange background.

⚠ CAUTION

Indicates a potentially hazardous situation. If not avoided, may result in minor or moderate injury. It may also alert against unsafe practices. This decal will have a yellow background.

NOTICE

Indicates information or a company policy that relates directly or indirectly to the safety of personnel or protection of property.

WARNING

This product must comply with all safety related bulletins. Contact JLG Industries, Inc. or the local authorized JLG representative for information regarding safety related bulletins which may have been issued for this product.

NOTICE

JLG Industries, Inc. sends safety related bulletins to the owner of record of this machine. Contact JLG Industries, Inc. to ensure that the current owner records are updated and accurate.

NOTICE

JLG Industries, Inc. must be notified immediately in all instances where JLG products have been involved in an accident involving bodily injury or death or when substantial damage has occurred to personal property or the JLG product.

Foreword

For:

- Accident Reporting
- Product Safety Publications
- Current Owner Updates
- Questions Regarding Product Safety
- Standards and Regulations Compliance Information
- Questions Regarding Special Product Applications
- Questions Regarding Product Modifications

Contact:

Product Safety and Reliability Department

JLG Industries, Inc.

13224 Fountainhead Plaza

Hagerstown, MD 21742

USA

or Visit www.jlg.com to find your local JLG office.

In USA:

Toll Free: 877-JLG-SAFE (877-554-7233)

Outside USA:

Phone: 240-420-2661

Fax: 301-745-3713

E-mail: ProductSafety@JLG.com

REVISION LOG

Date	Revision	Description
July 10, 2023	A	Original Issue

Other Publications Available

Publication	Publication Number
Service & Maintenance Manual	31222388
Illustrated Parts Manual	31222389

This Page is intentionally left blank

SECTION CONTENTS

Section	Subject	Page
FOREWORD		3
REVISION LOG		7
SECTION 1		
SAFETY PRECAUTIONS		13
1.1	General	13
1.2	Pre-Operation	13
1.3	Operation	15
1.4	Towing, Lifting, and Hauling	21
1.5	Maintenance	21
SECTION 2		
USER RESPONSIBILITIES, MACHINE PREPARATION, AND INSPECTION		25
2.1	Personnel Training	25
2.2	Preparation, Inspection, and Maintenance	26
2.3	1500SJ Machine Components	29
2.4	Pre-Start Inspection	32
2.5	1500SJ Walk-Around Inspection	34
2.6	Function Check	37
2.7	SkyGuard® Function Test	40
2.8	Boom Control System Check Procedure	41
SECTION 3		
MACHINE CONTROLS AND INDICATORS		43
3.1	General	43
3.2	Controls and Indicators	44
3.3	Ground Control Station	45
3.4	Ground Control Indicator Panel	52
3.5	Platform Control Station	54
3.6	Platform Control Indicator Panel	59

**SECTION 4
MACHINE OPERATION..... 63**

4.1	Description	63
4.2	Operating Characteristics and Limitations.....	63
4.3	Stability	67
4.4	Engine Operation.....	69
4.5	Air Shutoff Valve (ASOV) (If Equipped).....	72
4.6	Fuel Shutoff System (Reserve)	73
4.7	Capacity Select	74
4.8	Diesel Particulate Filter (If Equipped).....	74
4.9	Traveling (Driving).....	75
4.10	Traveling (Grade/Side Slope).....	76
4.11	Steering.....	78
4.12	Extending the Axles.....	78
4.13	Platform	79
4.14	Boom	79
4.15	Function Speed Control	82
4.16	USB Charging Port.....	82
4.17	Machine Safety System Override (MSSO) (If Equipped)	83
4.18	SkyGuard Operation	83
4.19	Emergency Towing.....	86
4.20	Shut Down and Park.....	87
4.21	Lifting and Tie Down	87
4.22	Lifting Chart	89
4.23	Safety Decals.....	90

**SECTION 5
LCD DISPLAY PANEL..... 97**

5.1	Description	97
5.2	Boot Up Splash Screen.....	97
5.3	Machine Operating Screen	98
5.4	Keyswitch In Ground Mode:.....	100
5.5	Function Speed	100
5.6	Can Bus Lost.....	101
5.7	Take Foot Out.....	102
5.8	Put Foot In	102
5.9	Boom Control System (BCS) Lamp On	103
5.10	Wire Rope Service	104
5.11	Platform Level	104

5.12	Platform Overload	105
5.13	Capacity Mode Error	105
5.14	Chassis Status	106
5.15	Machine Tilted Mode	108
5.16	Envelope Status	108
5.17	Machine Model Unknown	110
5.18	Selective Catalytic Reduction (SCR) Cleaning	111

SECTION 6

EMERGENCY PROCEDURES 113

6.1	General	113
6.2	Incident Notification	113
6.3	Emergency Operation	114
6.4	Emergency Towing Procedures	114
6.5	Machine Safety System Override (MSSO) (If Equipped)	115

SECTION 7

ACCESSORIES 117

7.1	Available Accessories and Relationship Table	117
7.2	Bolt-On External Fall Arrest	121
7.3	Cable Ladder Carrier	123
7.4	Fabric Mesh to Mid or Top Rail	124
7.5	Fall Arrest Platform	124
7.6	Nite Bright®	125
7.7	Pipe Racks	126
7.8	Platform Mesh to Mid or Top Rail	128
7.9	Platform Top Rail Extension	129
7.10	Platform Work Lights	130
7.11	Platform Work Surface	131
7.12	SkyCutter®	132
7.13	SkyGlazier®	135
7.14	SkyPower® 7.5 kW and Generator 4 kW	137
7.15	SkySense®	139
7.16	SkySense® Platform Bumper Padding	144
7.17	SkyWelder®	145
7.18	Soft Touch	148

**SECTION 8
GENERAL SPECIFICATIONS AND OPERATOR
MAINTENANCE 149**

- 8.1 General..... 149
- 8.2 Operating Specifications and Performance Data 149
- 8.3 Hydraulic Oil Specifications 153
- 8.4 Engine Oil Operating Temperature Specifications 155
- 8.5 Operator Maintenance and Lubrication Diagrams 158
- 8.6 Operator Maintenance..... 158
- 8.7 Tires and Wheels..... 169
- 8.8 Supplemental Information Only Applicable to CE/UKCA
Machines 171
- 8.9 EC Declaration of Conformity..... 172
- 8.10 UKCA Declaration of Conformity 173

SECTION 1

Safety Precautions

1.1 GENERAL

This section outlines the necessary precautions for proper and safe machine usage and maintenance. It is mandatory that a daily routine is established based on the content of this manual to promote proper machine usage. A maintenance program, using the information provided in this manual and the Service & Maintenance Manual, must also be established by a qualified person and must be followed to ensure that the machine is safe to operate.

The owner/user/operator/lessor/lessee of the machine must not accept operating responsibility until this manual has been read, training is accomplished, and operation of the machine has been completed under the supervision of an experienced and qualified operator.

This section contains the responsibilities of the owner, user, operator, lessor, and lessee concerning safety, training, inspection, maintenance, application, and operation. If there are any questions with regard to safety, training, inspection, maintenance, application, and operation, please contact JLG Industries, Inc. ("JLG").

⚠ WARNING

Failure to comply with the safety precautions listed in this manual could result in machine damage, property damage, personal injury or death.

1.2 PRE-OPERATION

1.2.1 Operator Training and Knowledge

- Read, understand, and study the Operation and Safety Manual in its entirety before operating the machine. For clarification, questions, or additional information regarding any portions of this manual, contact JLG Industries, Inc.

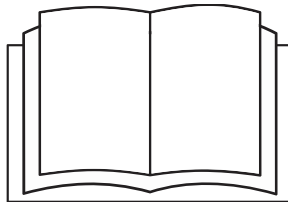

- Only personnel who have received proper training regarding the inspection, application and operation of MEWPs (including recognizing and avoiding hazards associated with their operation) shall be authorized to operate a MEWP.

Safety Precautions

- Only properly trained personnel who have received unit-specific familiarization shall operate a MEWP. The user shall determine if personnel are qualified to operate the MEWP prior to operation.
- Read, understand, and obey all DANGERS, WARNINGS, CAUTIONS, and operating instructions on the machine and in this manual.
- Ensure that the machine is to be used in a manner which is within the scope of its intended application as determined by JLG.
- All operating personnel must have a thorough understanding of the intended purpose and function of the MEWP controls, including platform, ground and emergency descent controls.
- Read, understand, and obey all applicable employer, local, and governmental regulations as they pertain to your utilization and application of the machine.

1.2.2 Workplace Inspection

- Precautions to avoid all hazards in the work area must be taken by the user before and during operation of the machine.
- Do not operate or raise the platform from a position on trucks, trailers, railway cars, floating vessels, scaffolds or other equipment unless the application is approved in writing by JLG.
- Before operation, check work area for overhead hazards such as electric lines, bridge cranes, and other potential overhead obstructions.
- Check operating surfaces for holes, bumps, drop-offs, obstructions, debris, concealed holes, and other potential hazards.
- Check the work area for hazardous locations. Do not operate the machine in hazardous environments unless approved for that purpose by JLG.
- Ensure that the ground conditions are adequate to support the maximum tire load indicated on the tire load decals located on the chassis adjacent to each wheel. Do not travel on unsupported surfaces.

1.2.3 Machine Inspection

- Do not operate this machine until the inspections and functional checks as specified in the User Responsibilities, Machine Preparation, and Inspection Section of this manual have been performed.
- Do not operate this machine until it has been serviced and maintained according to the maintenance and inspection requirements as specified in the machine's Service Manual.
- Ensure all safety devices are operating properly. Modification of these devices is a safety violation.

WARNING

Modification or alteration of a MEWP shall be made only with prior written permission from the manufacturer.

- Do not operate any machine on which the safety or instruction placards or decals are missing or illegible.
- Check the machine for modifications to original components. Ensure that any modifications have been approved by JLG.
- Avoid accumulation of debris on platform floor. Keep mud, oil, grease, and other slippery substances from footwear and platform floor.

1.3 OPERATION

1.3.1 General

- Machine operation requires your full attention. Bring the machine to a full stop before using any device, i.e. cell phones, two-way radios, etc. that will distract your attention from safely operating the machine.
- Do not use the machine for any purpose other than positioning personnel, their tools, and equipment.
- Before operation, the user must be familiar with the machine capabilities and operating characteristics of all functions.
- Never operate a malfunctioning machine. If a malfunction occurs, shut down the machine. Remove the unit from service and notify the proper authorities.
- Do not remove, modify, or disable any safety devices.
- Never slam a control switch or lever through neutral to an opposite direction. Always return switch to neutral and stop before moving the switch to the next function. Operate controls with slow and even pressure.
- Do not allow personnel to tamper with or operate the machine from the ground with personnel in the platform, except in an emergency.
- Do not carry materials directly on platform railing unless approved by JLG.
- When two or more persons are in the platform, the operator shall be responsible for all machine operations.
- Always ensure that power tools are properly stowed and never left hanging by their cord from the platform work area.
- When driving, always position boom over rear axle in line with the direction of travel. Remember, if boom is over the front axle, steer and drive functions will be reversed.

Safety Precautions

- Do not assist a stuck or disabled machine by pushing or pulling except by pulling at the chassis tie-down lugs.
- Fully lower platform and shut off all power before leaving machine.
- Remove all rings, watches, and jewelry when operating machine. Do not wear loose fitting clothing or long hair unrestrained which may become caught or entangled in equipment.
- Persons under the influence of drugs or alcohol or who are subject to seizures, dizziness or loss of physical control must not operate this machine.
- Hydraulic cylinders are subject to thermal expansion and contraction. This may result in changes to the platform position while the machine is stationary. Factors affecting thermal movement can include the length of time the machine will remain stationary, hydraulic oil temperature, ambient air temperature, and platform position.

1.3.2 Trip and Fall Hazards

- Before operating the machine, ensure all gates are closed and fastened in their proper position.

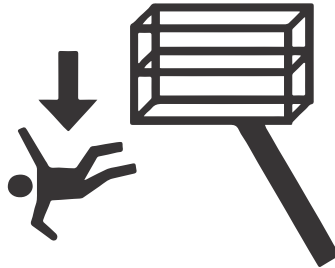

- During operation, occupants in the platform must wear a full body harness with a lanyard attached to an authorized lanyard anchorage point. Attach only one (1) lanyard per lanyard anchorage point.

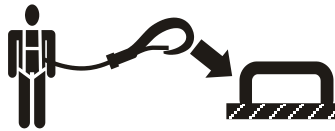

- Enter and exit only through gate area. Use extreme caution when entering or leaving platform. Ensure that the platform assembly is fully lowered. Face the platform when entering or leaving the platform. Always maintain “three point contact” with the machine, using two hands and one foot or two feet and one hand at all times during entry and exit.

- Keep both feet firmly positioned on the platform floor at all times. Never position ladders, boxes, steps, planks, or similar items on unit to provide additional reach for any purpose.
- Keep oil, mud, and slippery substances cleaned from footwear and the platform floor.

1.3.3 Electrocutation Hazards

- This machine is not insulated and does not provide protection from contact with or proximity to electrical current.
- It is not recommended to use the machine during lightning. To prevent injury or machine damage if lightning occurs during operation, lower the boom and shut down the machine in a safe and secure location.

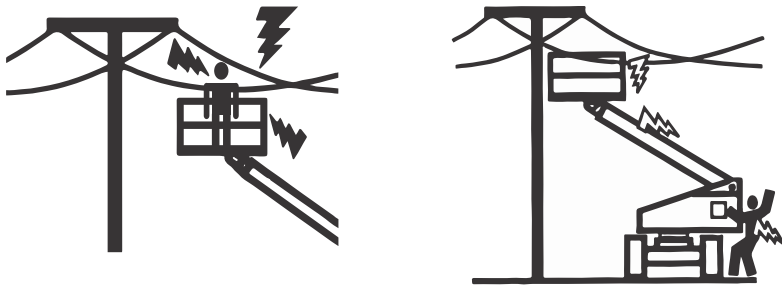

- Maintain distance from electrical lines, apparatus, or any energized (exposed or insulated) parts according to the Minimum Approach Distance (MAD) as shown in [Table — Minimum Approach Distances \(MAD\), page 17](#).
- Allow for machine movement and electrical line swaying.

Table 1. Minimum Approach Distances (MAD)

Voltage Range (Phase to Phase)	Minimum Approach Distance in Feet (Meters)
0 to 50 KV	10 (3)
Over 50K V to 200 KV	15 (5)
Over 200 KV to 350 KV	20 (6)
Over 350 KV to 500 KV	25 (8)
Over 500 KV to 750 KV	35 (11)

Table 1. Minimum Approach Distances (MAD) (continued)

Voltage Range (Phase to Phase)	Minimum Approach Distance in Feet (Meters)
Over 750 KV to 1000 KV	45 (14)

Note: This requirement shall apply except where employer, local or governmental regulations are more stringent.

- Maintain a clearance of at least 10 ft (3m) between any part of the machine and its occupants, their tools, and their equipment from any electrical line or apparatus carrying up to 50,000 volts. One foot additional clearance is required for every additional 30,000 volts or less.
- The MAD may be reduced if insulating barriers are installed to prevent contact, and the barriers are rated for the voltage of the line being guarded. These barriers shall not be part of (or attached to) the machine.
- The MAD shall be reduced to a distance within the designed working dimensions of the insulating barrier. This determination shall be made by a qualified person with respect to electrical transmission and distribution in accordance with the employer, local, or governmental requirements for work practices near energized equipment.

⚠ DANGER

Do not maneuver machine or personnel inside prohibited zone (MAD). Assume all electrical parts and wiring are energized unless known otherwise.

1.3.4 Tipping Hazards

- Ensure that the ground conditions are adequate to support the maximum tire load indicated on the tire load decals located on the chassis adjacent to each wheel. Do not travel on unsupported surfaces.
- The user must be familiar with the operating surface before driving. Do not exceed the allowable side slope and grade while driving.

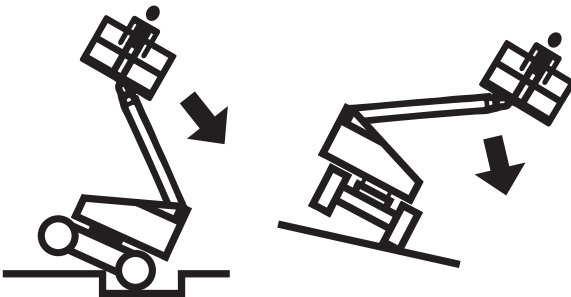

- Do not elevate platform or drive with platform elevated while on or near a sloping, uneven, or soft surface.

- Ensure machine is positioned on a smooth, firm surface within the limits of the maximum operating slope before elevating platform or driving with the platform in the elevated position.
- Before driving on floors, bridges, trucks, and other surfaces, check allowable capacity of the surfaces.
- Never exceed the maximum platform capacity as specified on the platform. Keep all loads within the confines of the platform, unless authorized by JLG.
- Keep the chassis of the machine a minimum of 2 ft (0.6m) from holes, bumps, drop-offs, obstructions, debris, concealed holes, and other potential hazards at the ground level.
- Do not push or pull any object with the boom.
- Never attempt to use the machine as a crane. Do not tie-off machine to any adjacent structure. Never attach wire, cable, or any similar items to platform.
- If boom assembly or platform is in a position that one or more wheels are off the ground, all persons must be removed before attempting to stabilize the machine. Use cranes, forklift trucks, or other appropriate equipment to stabilize machine.
- Do not operate the machine when wind conditions, including gusts, exceed 28 mph (12.5 m/s). Refer to [Table — Beaufort Scale \(For Reference Only\), page 20](#). Factors affecting wind speed are; platform elevation, surrounding structures, local weather events, and approaching storms.
- Wind speed can be significantly greater at height than at ground level.
- Wind speed can change rapidly. Always consider approaching weather events, the time required to lower the platform, and methods to monitor current and potential wind conditions.
- Do not cover or increase surface area of the platform or the load. Do not carry large surface area items in the platform when operating outdoors. The addition of such items increases the exposed wind area of the machine. Increased areas exposed to wind will decrease stability.
- Do not increase the platform size with unauthorized modifications or attachments.

WARNING

Do not operate the machine when wind conditions exceed specifications shown in the General Specifications section of this manual or as shown on the capacity placard on the platform billboard.

Table 2. Beaufort Scale (For Reference Only)

Beaufort Number	Wind Speed		Description	Land Conditions
	mph	m/s		
0	0	0-0.2	Calm	Calm. Smoke rises vertically
1	1-3	0.3-1.5	Light air	Wind motion visible in smoke
2	4-7	1.6-3.3	Light breeze	Wind felt on exposed skin. Leaves rustle
3	8-12	3.4-5.4	Gentle breeze	Leaves and smaller twigs in constant motion
4	13-18	5.5-7.9	Moderate breeze	Dust and loose paper raised. Small branches begin to move.
5	19-24	8.0-10.7	Fresh breeze	Smaller trees sway.
6	25-31	10.8-13.8	Strong breeze	Large branches in motion. Flags waving near horizontal. Umbrella use becomes difficult.
7	32-38	13.9-17.1	Near Gale/Moderate Gale	Whole trees in motion. Effort needed to walk against the wind.
8	39-46	17.2-20.7	Fresh Gale	Twigs broken from trees. Cars veer on road.
9	47-54	20.8-24.4	Strong Gale	Light structure damage.

1.3.5 Crushing and Collision Hazards

- Approved head gear must be worn by all operating and ground personnel.
- Watch for obstructions around machine and overhead when driving. Check clearances above, on sides, and bottom of platform during all operations.

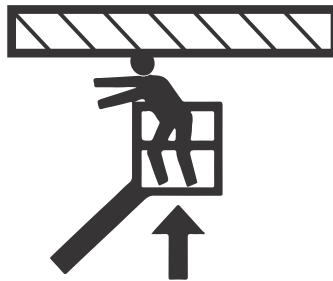

- During operation, keep all body parts inside platform railing.
- Use the boom functions, not the drive function, to position the platform close to obstacles.
- Always post a lookout when driving in areas where vision is obstructed.
- Keep non-operating personnel at least 6 ft (1.8 m) away from machine during all operations.

- Under all travel conditions, the operator must limit travel speed according to conditions of ground surface, congestion, visibility, slope, location of personnel, and other factors.
- Be aware of stopping distances in all drive speeds. When driving in high speed, reduce drive speed before stopping. Travel grades in low speed only.
- Do not use high speed drive in restricted or close quarters or when driving in reverse.
- Exercise extreme caution at all times to prevent obstacles from striking or interfering with operating controls and persons in the platform.
- Ensure that operators of other overhead and floor level machines are aware of the MEWP's presence. Disconnect power to overhead cranes. Barricade floor area if necessary.
- Do not operate over ground personnel. Warn personnel not to work, stand, or walk under a raised boom or platform. Position barricades on floor if necessary.

1.4 TOWING, LIFTING, AND HAULING

- Never allow personnel in platform while towing, lifting, or hauling.
- This machine should not be towed, except in the event of emergency, malfunction, power failure, or loading/unloading. Refer to the Emergency Procedures section of this manual for emergency towing procedures.
- Ensure boom is in the stowed position and, if equipped, the turntable locked prior to towing, lifting or hauling. The platform must be completely empty of tools.
- When lifting machine, lift only at designated areas of the machine. Lift the unit with equipment of adequate capacity.
- Refer to the Machine Operation section of this manual for lifting information.

1.5 MAINTENANCE

This sub-section contains general safety precautions which must be observed during maintenance of this machine. Additional precautions to be observed during machine maintenance are inserted at the appropriate points in this manual and in the Service and Maintenance Manual. It is of utmost importance that maintenance personnel pay strict attention to these precautions to avoid possible injury to personnel or damage to the machine or property. A maintenance program must be established by a qualified person and must be followed to ensure that the machine is safe.

1.5.1 Maintenance Hazards

- Shut off power to all controls and ensure that all moving parts are secured from inadvertent motion prior to performing any adjustments or repairs.

Safety Precautions

- Never work under an elevated platform until it has been fully lowered to the full down position, if possible, or otherwise supported and restrained from movement with appropriate safety props, blocking, or overhead supports.
- DO NOT attempt to repair or tighten any hydraulic hoses or fittings while the machine is powered on or when the hydraulic system is under pressure.
- Always relieve hydraulic pressure from all hydraulic circuits before loosening or removing hydraulic components.
- DO NOT use your hand to check for leaks. Use a piece of cardboard or paper to search for leaks. Wear gloves to help protect hands from spraying fluid.



- Use only replacement parts or components that are approved by JLG. To be considered approved, replacement parts or components must be identical or equivalent to original parts or components.
- Never attempt to move heavy parts without the aid of a mechanical device. Do not allow heavy objects to rest in an unstable position. Ensure adequate support is provided when raising components of the machine.
- Do not use machine as a ground for welding.
- When performing welding or metal cutting operations, precautions must be taken to protect the chassis from direct exposure to weld and metal cutting spatter.
- Do not refuel combustion engine-powered machines with the engine running.
- Use only approved non-flammable cleaning solvents.
- Do not replace items critical to stability, such as batteries or solid tires, with items of different weight or specification. Do not modify the MEWP in any way to affect stability.
- Refer to the Service & Maintenance Manual for the weights of critical stability items.

⚠ WARNING

Modification or alteration of a MEWP shall be made only with prior written permission from the manufacturer.

1.5.2 Battery Hazards

- Always disconnect batteries when servicing electrical components or when performing welding on the machine.
- Do not allow smoking, open flame, or sparks near battery during charging or servicing.
- Do not contact tools or other metal objects across the battery terminals.
- Always wear hand, eye, and face protection when servicing batteries. Ensure that battery acid does not come in contact with skin or clothing.

CAUTION

Battery fluid is highly corrosive. Avoid contact with skin and clothing at all times. Immediately rinse any contacted area with clean water and seek medical attention.

- Charge batteries only in a well ventilated area.
- Avoid overfilling the battery fluid level. Add distilled water to batteries only after the batteries are fully charged.

This Page is intentionally left blank

SECTION 2

User Responsibilities, Machine Preparation, and Inspection

2.1 PERSONNEL TRAINING

The Mobile Elevating Work Platform (MEWP) is a personnel handling device, so it is necessary that it be operated and maintained only by trained personnel.

2.1.1 Operator Training

Operator training must cover:

1. Reading and understanding the Operation and Safety Manual.
2. Thorough understanding of the intended purpose and function of the MEWP controls, including platform, ground, and emergency descent controls.
3. Control labels, instructions, and warnings on the machine.
4. Applicable regulations, standards, and safety rules.
5. Use of approved fall protection equipment.
6. Enough knowledge of the mechanical operation of the machine to recognize a malfunction or potential malfunction.
7. The safest means to operate the machine where overhead obstructions, other moving equipment, and obstacles, depressions, holes, and drop-offs exist.
8. Means to avoid the hazards of unprotected electrical conductors.
9. Selection of the appropriate MEWP and available options for the work to be performed considering specific job requirements, with involvement from the MEWP owner, user, and/ or supervisor.
10. The responsibility of the operator to ensure all platform occupants have a basic level of knowledge to work safely on the MEWP, and to inform them of applicable regulations, standards, and safety rules.
11. The requirement for familiarization in addition to training.

2.1.2 Training Supervision

Training must be delivered by a qualified person in an open area free of hazards until the trainee has demonstrated the ability to safely control and operate the machine.

2.1.3 Operator Responsibility

The operator must be instructed that they have the responsibility and authority to shut down the machine in case of a malfunction or other unsafe condition of either the machine or the job site.

2.1.4 Machine Familiarization

Note: Responsibilities for familiarization may vary by region.

Only properly trained personnel who have received unit-specific familiarization shall operate a MEWP. The user shall determine if personnel are qualified to operate the MEWP prior to operation. The user shall ensure that after familiarization, the operator operates the MEWP for a sufficient period of time to achieve proficiency. When authorized by the user, self-familiarization can be achieved, if authorized, by a properly trained operator reading, understanding and following the manufacturer's operator's manual.

Prior to user's authorization of an operator to use a specific model of MEWP, the user shall ensure the operator is familiarized on the following:

1. Location of the manual storage compartment and the requirement to ensure the required manual(s) are present on the MEWP;
2. Purpose and function of the machine controls and indicators at the platform and ground control stations;
3. Purpose, location, and function of the emergency controls;
4. Operating characteristics and limitations;
5. Features and devices;
6. Accessories and optional equipment.

2.2 PREPARATION, INSPECTION, AND MAINTENANCE

The following table covers machine inspections and maintenance required by JLG Industries, Inc. Consult local regulations for further requirements for MEWPs. The frequency of inspections and maintenance must be increased as necessary when the machine is used in a harsh or hostile environment, if the machine is used with increased frequency, or if the machine is used in a severe manner.

Table 3. Inspection and Maintenance Table

Type	Frequency	Primary Responsibility	Service Qualification	Reference
Pre-Start Inspection	Before using each day; or whenever there is an Operator change	User or Operator	User or Operator	Operation & Safety Manual
Pre-Delivery Inspection (See Note)	Before each sale, lease, or rental delivery	Owner, Dealer, or User	Qualified JLG Mechanic	Service & Maintenance Manual and applicable JLG inspection form
Frequent Inspection (See Note)	In service for 3 months or 150 hours, whichever comes first or Out of service for a period of more than 3 months or Purchased used	Owner, Dealer, or User	Qualified JLG Mechanic	Service & Maintenance Manual and applicable JLG inspection form
Annual Machine Inspection (See Note)	Annually, no later than 13 months from the date of prior inspection	Owner, Dealer, or User	Factory Trained Service Technician (Recommended)	Service & Maintenance Manual and applicable JLG inspection form

Table 3. Inspection and Maintenance Table (continued)

Type	Frequency	Primary Responsibility	Service Qualification	Reference
Preventive Maintenance	At intervals as specified in the Service & Maintenance Manual	Owner, Dealer, or User	Qualified JLG Mechanic	Service & Maintenance Manual

Note: Inspection forms are available from JLG. Use the Service & Maintenance Manual to perform inspections.

NOTICE

JLG Industries, Inc. recognizes a factory trained service technician as a person who has successfully completed the JLG Service Training School for the specified JLG product model.

2.3 1500SJ MACHINE COMPONENTS

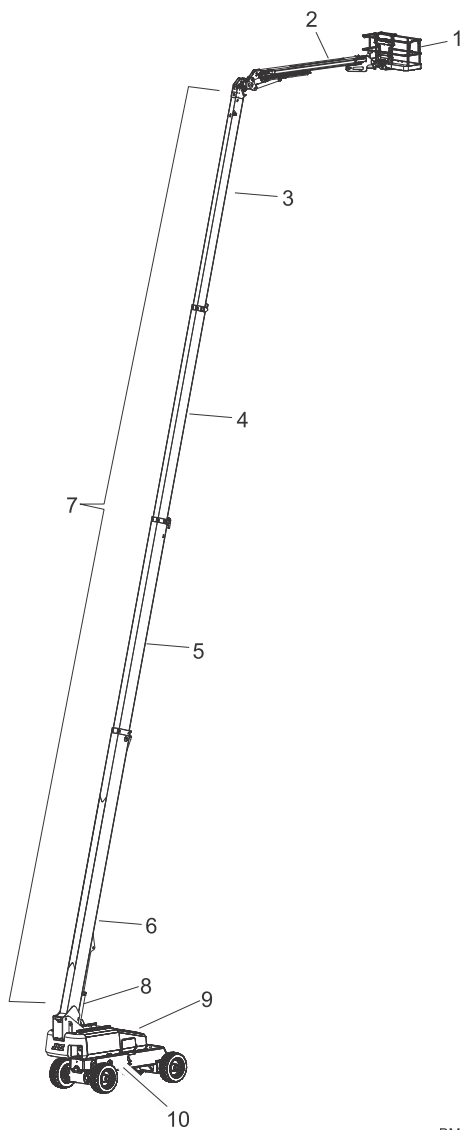

BM000311

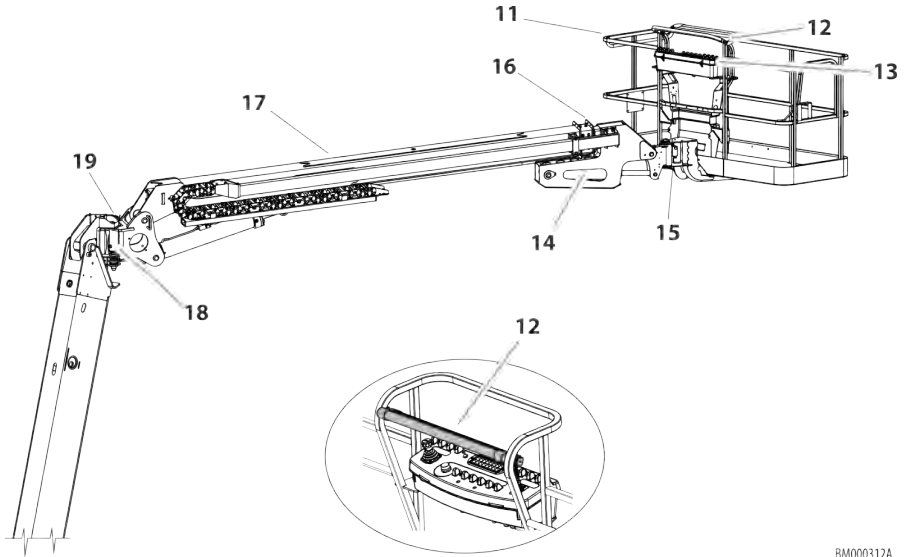

BM000312A

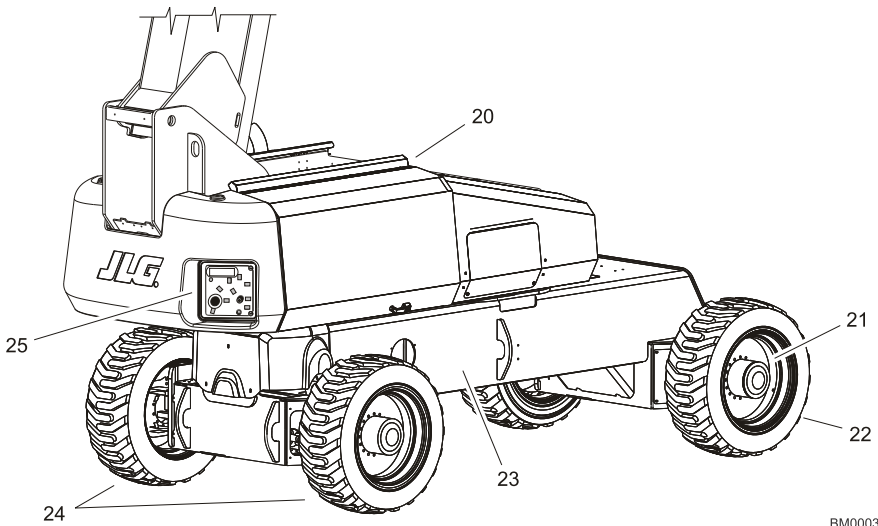

BM00031:

Machine Components

- | | | |
|---------------------------|------------------------------|--------------------------------|
| 1. Platform | 10. Chassis | 19. Jib Rotator |
| 2. Jib | 11. Platform | 20. Turntable |
| 3. Fly Boom Section | 12. SkyGuard | 21. Drive hub |
| 4. Outer Mid Boom Section | 13. Platform Control Console | 22. Rear Drive Wheels |
| 5. Inner Mid Boom Section | 14. Platform Level Cylinder | 23. Frame |
| 6. Base Boom Section | 15. Platform Rotator | 24. Front Drive / Steer Wheels |
| 7. Boom Assembly | 16. Jib Fly Boom | 25. Ground Control Console |
| 8. Lift Cylinder | 17. Jib Base Boom | |
| 9. Turntable | 18. Jib Lock Cylinder | |

2.4 PRE-START INSPECTION

The Pre-Start Inspection should include each of the following:

1. **Cleanliness** — Check all surfaces for leakage (oil, fuel, or battery fluid) or foreign objects. Report any leakage to the proper maintenance personnel.
2. **Structure** — Inspect the machine structure for dents, damage, weld or parent metal cracks or other discrepancies.

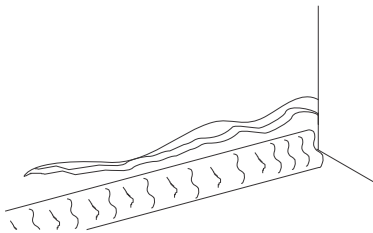

Figure 1. Parent Metal Crack

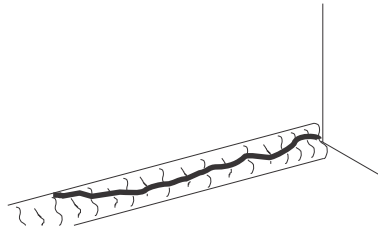

Figure 2. Weld Crack

3. **Decals and Placards** — Check all for cleanliness and legibility. Make sure none of the decals and placards are missing. Make sure all illegible decals and placards are cleaned or replaced.
4. **Operation and Safety Manuals** — Make sure a copy of the Operation and Safety Manual, AEM Safety Manual (ANSI markets only), and ANSI Manual of Responsibilities (ANSI markets only) is enclosed in the weather resistant storage container.
5. **Walk-Around Inspection** — Perform as instructed.
6. **Battery** — Charge as required.
7. **Fuel (Combustion Engine Powered Machines)** – Add the proper fuel as necessary.
8. **Engine Oil Supply** — Ensure the engine oil level is at the Full mark on the dipstick and the filler cap is secure.
9. **Hydraulic Oil** — Check the hydraulic oil level. Ensure hydraulic oil is added as required.
10. **Accessories/Attachments** — Refer to the Accessories section in this manual or the accessory installed upon the machine for specific inspection, operation, and maintenance instructions.
11. **Function Check** — Once the Walk-Around Inspection is complete, perform a functional check of all systems in an area free of overhead and ground level obstructions. Refer to Section 4 for more specific operating instructions.

12. **Boom Control System Check** — Perform a check of the boom control system as specified in this section.
13. **Platform Gate** — Keep gate and surrounding area clean and unobstructed. Verify the gate closes properly and is not bent or damaged. Keep gate closed at all times except when entering/exiting the platform and loading/unloading materials.
14. **Lanyard Attach Points** — During operation, occupants in the platform must wear a full body harness with a lanyard attached to an authorized lanyard anchorage point. Attach only one (1) lanyard per lanyard anchorage point.

WARNING

If the machine does not operate properly, turn off the machine immediately! Report the problem to the proper maintenance personnel. Do not operate the machine until it is declared safe for operation.

2.5 1500SJ WALK-AROUND INSPECTION

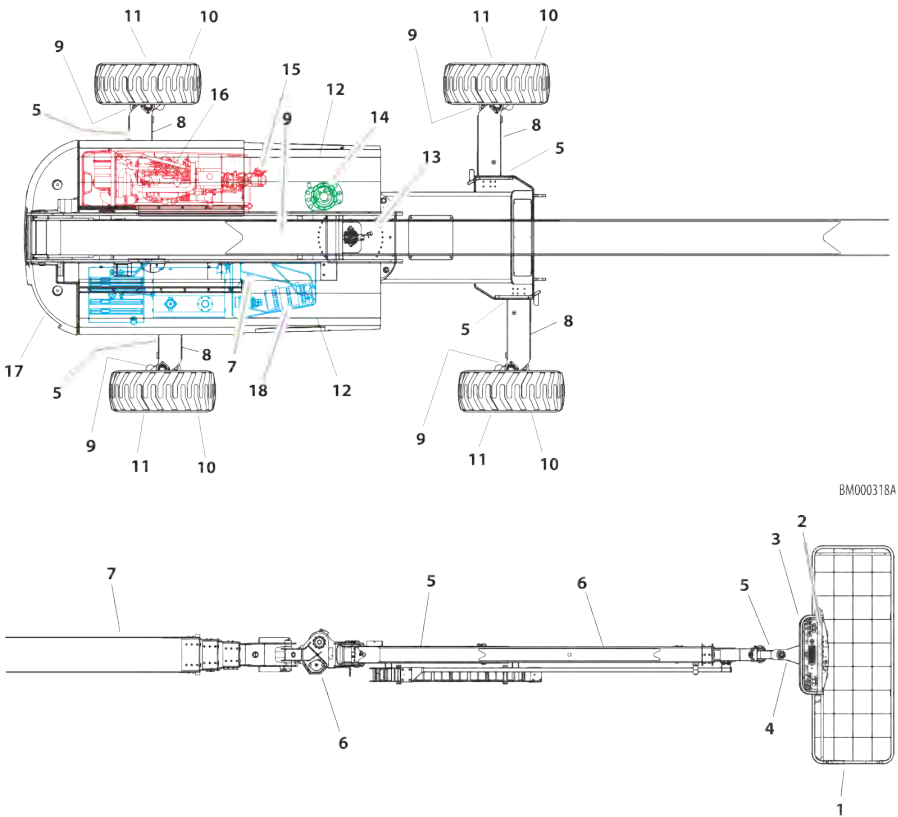

2.5.1 General

Begin the Walk-Around Inspection at Item 1, as noted on the diagram. Continue checking each item in sequence for the conditions listed in the following checklist.

WARNING

To avoid possible injury, be sure machine power is off. Do not operate machine until all malfunctions have been corrected.

NOTICE

Do not overlook visual inspection of chassis underside. Checking this area may result in discovery of conditions which could cause extensive machine damage.

INSPECTION NOTE: On all components, make sure there are no loose or missing parts, that they are securely fastened, and no visible damage, leaks or excessive wear exists in addition to any other criteria mentioned.

1. **Platform Assembly and Gate** - Footswitch works properly, not modified, disabled or blocked. Gate latches and hinges in working condition.
2. **SkyGuard** - See Inspection Note.
3. **Platform Control Console** - Switches and levers return to neutral when activated and released, decals/placards secure and legible, control markings legible.
4. **Platform Rotator** - See Inspection Note.
5. **All Hydraulic Cylinders** - No visible damage; pivot pins and hydraulic hoses undamaged, not leaking.
6. **Jib, Jib Rotator and Jib Lock Cylinder** - See Inspection Note.
7. **Boom Sections/Turntable** - See Inspection Note.
8. **Axles** - See Inspection Note.
9. **Steering Spindles and Sensors** - See Inspection Note.
10. **Wheel/Tire Assemblies** - Properly secured, no missing lug nuts. Inspect for worn tread, cuts, tears or other discrepancies. Inspect wheels for damage and corrosion.
11. **Drive Motor, Brake, and Hub** - No evidence of leakage.
12. **Hood Assemblies** - See Inspection Note.
13. **Turntable Bearing** - Evidence of proper lubrication. No evidence of loose bolts or looseness between bearing and structure.
14. **Swing Drive** - No evidence of damage.
15. **Hydraulic Pump** - See Inspection Note.
16. **Air Shutoff Valve (ASOV) (If Equipped)** - See Inspection Note.
17. **Ground Control Console** - Switches and levers return to neutral when activated and released, decals/placards secure and legible, control markings legible.

18. **Auxiliary Hydraulic Pump** - See Inspection Note.

2.6 FUNCTION CHECK

WARNING

To avoid serious injury, do not operate machine if any control levers or toggle switches controlling platform movements do not return to the off position when released.

WARNING

To avoid a collision and injury if platform does not stop when a control switch or lever is released, remove foot from footswitch or use emergency stop to stop machine.

Perform the Function Check as follows:

1. From the ground control panel with no load in the platform:
 - a. Ensure that all machine functions are disabled when the Emergency Stop Button is pushed in.
 - b. Ensure all functions stop when the function switch is released.
 - c. Operate all functions and ensure proper operation.
 - d. Raise main boom approximately horizontal, then extend and retract boom sections. All boom sections should extend/retract together at the same rate of speed. Any difference would indicate delayed movement and loose wire ropes.

WARNING

If delayed movement is detected in wire rope operation, lower platform to stowed position, shut down machine, and have wire ropes inspected/ serviced by a factory trained service technician. Loose or misadjusted wire ropes could result in serious injury or death.

2. Check the Boom Control System. Refer to Boom Control System Check Procedure in this section.

3. From the platform control console:
 - a. Ensure the control console is firmly secured in the proper location.
 - b. Check all guards protecting the switches or locks are in place.
 - c. Ensure that all machine functions are disabled when the Emergency Stop Button is pushed in.
 - d. Ensure that all machine functions stop when the footswitch is released.
 - e. Operate all functions and ensure proper operation.
 - f. Raise main boom approximately horizontal, then extend and retract boom sections. All boom sections should extend/retract together at the same rate of speed. Any difference would indicate delayed movement and loose wire ropes.

WARNING

If delayed movement is detected in wire rope operation, lower platform to stowed position, shut down machine, and have wire ropes inspected/ serviced by a factory trained service technician. Loose or misadjusted wire ropes could result in serious injury or death.

4. With the platform in the stowed position:
 - a. Drive the machine on a grade, not to exceed the maximum operating slope, and stop to ensure the brakes hold.
 - b. Ensure the tilt indicator is illuminated to ensure proper operation.
 - c. Check that the boom telescope (beyond transport mode), lift up (more than 5° above horizontal), and swing (beyond 35° from center) functions are disabled with the axles retracted.
5. With the jib in line with the boom and locked, make sure the jib will not unlock unless:
 - a. The machine is in transport position (booms retracted and main boom below 5° elevation).
 - b. Jib boom retracted; axles retracted.
 - c. The boom capacity select switch is in 500 lb mode.
6. With the jib in the stowed position, make sure the jib will not swing unless:
 - a. The jib is fully retracted.
 - b. The machine is in transport position (booms retracted, main boom below 5° elevation, and axles retracted).
7. Extend the axles and swing the boom over either of the rear tires and ensure the Drive Orientation indicator illuminates and the Drive Orientation Override switch must be used for the drive function to operate.

8. With the machine positioned on a smooth, firm surface within the limits of the maximum operating slope, elevate the boom above 5° of horizontal; Select high speed drive mode. Carefully attempt to drive and ensure the drive speed is reduced.

2.7 SKYGUARD® FUNCTION TEST

Note: Refer to [Section — SkyGuard Operation](#) for additional information on SkyGuard operation.

From the Platform Console in an area free from obstructions:

1. Operate the telescope out function.
2. Activate the SkyGuard sensor:
 - a. **SkyGuard** — Apply approximately 50 lb (222 Nm) of force to yellow bar.
 - b. **SkyGuard SkyLine®** — Press rod to break connection between the rod and the right bracket.
 - c. **SkyGuard SkyEye®** — Put arm or hand in path of sensor beam.
3. Once the sensor has been activated, verify the following conditions:
 - a. Telescope out function stops and telescope in function operates for a short duration.
 - b. The horn sounds.
 - c. If equipped with SkyGuard beacon, the beacon illuminates.

Note: If SkyGuard is enabled with the Soft Touch system, functions will cut out instead of reversing.

4. Disengage the SkyGuard sensor, release controls, then recycle the foot switch. Ensure normal operation is available.

Note: On machines equipped with SkyLine, reattach the rod to the right bracket.

If SkyGuard remains activated after function reversal or cutout, press and hold the SkyGuard Override Switch to allow normal use of machine functions until the sensor is disengaged.

2.8 BOOM CONTROL SYSTEM CHECK PROCEDURE

Perform the following check with no load (personnel or material) in the platform from the ground control console.

1. Ensure all axles are fully extended.
2. With the boom fully retracted, raise the boom off the boom rest to horizontal.
3. Position the jib horizontal (if equipped) and platform level.
4. Extend the boom until it stops.
5. Push and hold the Boom Control System Test button. The lighting of the green Boom Control System Calibrated indicator indicates the system is functioning properly. No indicator light or the lighting of the red Boom Control System Warning indicator indicates the system must be repaired by JLG authorized Service Personnel before the machine can be used.

This Page is intentionally left blank

SECTION 3

Machine Controls and Indicators

3.1 GENERAL

NOTICE

The manufacturer has no direct control over machine application and operation. The user and operator are responsible for conforming with good safety practices.

This section provides the necessary information needed to understand control functions.

3.2 CONTROLS AND INDICATORS

Note: The indicator panels use different shaped symbols to alert the operator to different types of operational situations that could arise. The meaning of those symbols are explained below.



Indicates a potentially hazardous situation, which if not corrected, could result in serious injury or death. This indicator will be red.



Indicates an abnormal operating condition, which if not corrected, may result in machine interruption or damage. This indicator will be yellow.



Indicates important information regarding the operating condition, i.e. procedures essential for safe operation. This indicator will be green with the exception of the capacity indicator which will be yellow.

3.3 GROUND CONTROL STATION

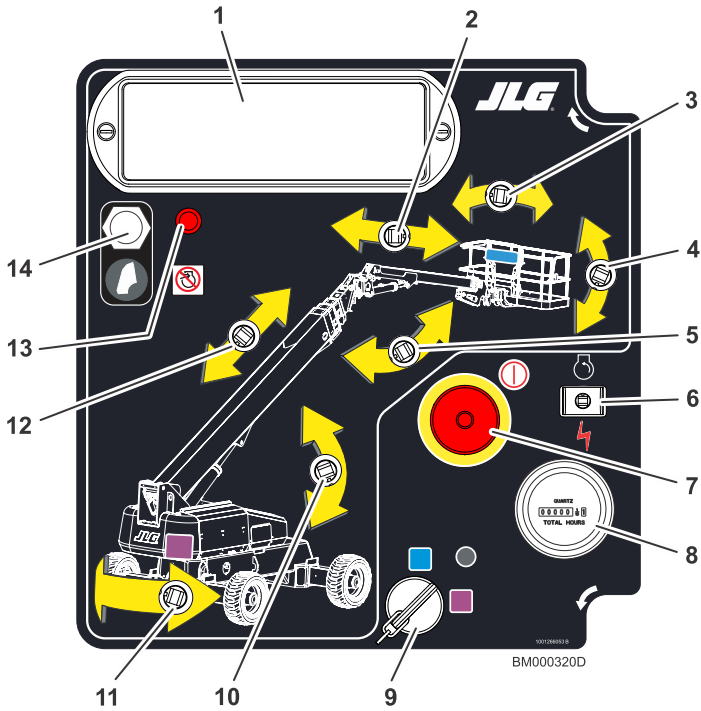

1500SJ Ground Control Station

- | | |
|--|--|
| 1. Indicator Panel | 10. Main Boom Lift |
| 2. Jib Telescope | 11. Swing |
| 3. Platform Rotate | 12. Main Boom Telescope |
| 4. Platform Leveling Override Switch | 13. Air Shutoff Valve (ASOV) (If Equipped) |
| 5. Jib Lift | 14. Boom Control System Test Button |
| 6. Engine Start / Auxiliary Power Switch | |
| 7. Power / Emergency Stop Switch | |
| 8. Hourmeter | |
| 9. Platform / Ground Select Switch | |

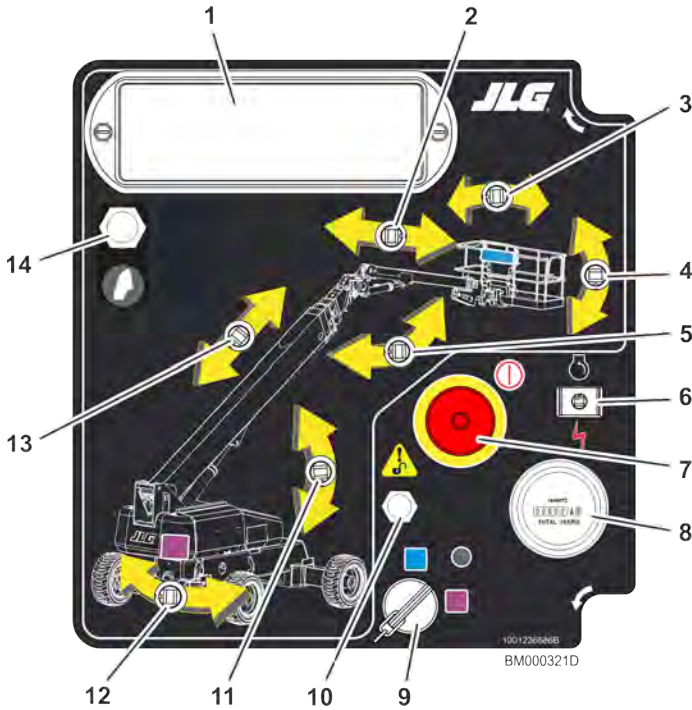

1500SJ Ground Control Station with MSSO

- | | |
|------------------------------------|---|
| 1. Indicator Panel | 10. Machine Safety System Override (MSSO) (If Equipped) |
| 2. Jib Telescope | 11. Main Boom Lift |
| 3. Platform Rotate | 12. Swing |
| 4. Platform Leveling Override | 13. Main Boom Telescope |
| 5. Jib Lift | 14. Boom Control system Test Button |
| 6. Engine Start / Auxiliary Power | |
| 7. Power / Emergency Stop | |
| 8. Hourmeter | |
| 9. Platform / Ground Select Switch | |

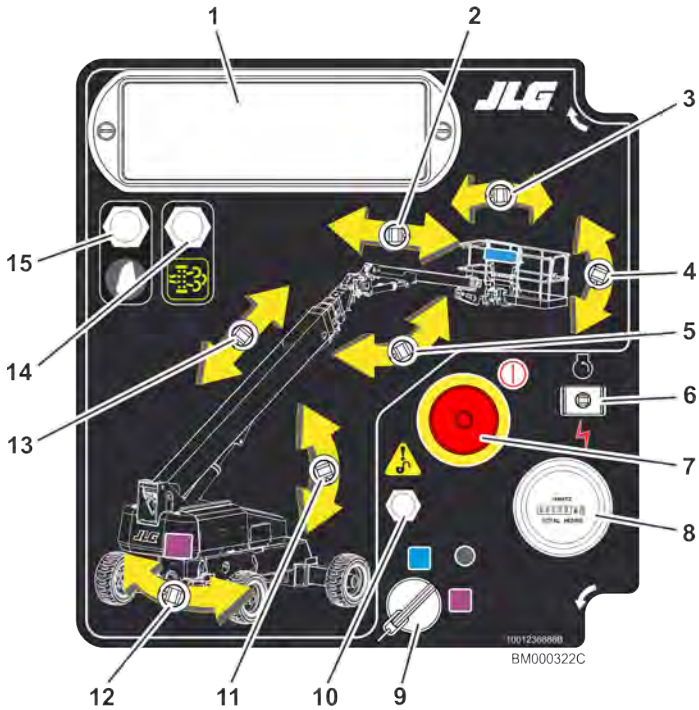

1500SJ Ground Control Station with MSSO and DPF

- | | |
|------------------------------------|---|
| 1. Indicator Panel | 10. Machine Safety System Override (MSSO) (If Equipped) |
| 2. Jib Telescope | 11. Main Boom Lift |
| 3. Platform Rotate | 12. Swing |
| 4. Platform Leveling Override | 13. Main Boom Telescope |
| 5. Jib Lift | 14. Diesel Particulate Filter (DPF) |
| 6. Engine Start / Auxiliary Power | 15. Boom Control system Test Button |
| 7. Power / Emergency Stop | |
| 8. Hourmeter | |
| 9. Platform / Ground Select Switch | |

3.3.1 Ground Control Station Functions

⚠ WARNING

When operating the boom ensure there are no personnel around or under platform.

⚠ WARNING

To avoid serious injury, do not operate machine if any control levers or toggle switches controlling platform movement do not return to the off or neutral position when released.

Note: When machine is shut down the Platform/ Ground Select switch and Emergency Stop must be positioned to Off.

To operate machine from the platform, the Platform/Ground Select switch must be turned to the blue square.

To operate the machine from the ground, the Platform/Ground Select switch must be turned to the purple square.



Air Shutoff Valve (ASOV) (If Equipped)

The red LED ASOV light indicates when the valve has been actuated.



Boom Control System Test Button

The push button is used to test the boom control system and confirm that is working properly.



Diesel Particulate Filter (DPF) (If Equipped)

This button initiates the standstill exhaust system cleaning.



Engine Start / Auxiliary Power Switch

To start the engine, the switch must be held up until the engine starts.



Note: When the glow plug indicator is illuminated on machines equipped with diesel engines, wait until the light goes out before cranking the engine.

To use auxiliary power, the switch must be held down for the duration of auxiliary pump use.



CAUTION

When operating on auxiliary power, do not operate more than one function at a time. Simultaneous operation can overload the auxiliary pump motor.

Hourmeter

Registers the amount of time the machine has been in use with the engine running. By connecting into the oil pressure circuit of the engine, only engine hours are recorded. The hourmeter registers up to 9,999.9 hours and cannot be reset.



Indicator Panel

The Indicator Panel contains indicator lights which signal problem conditions or functions operating during machine operation.



Jib

Provides raising and lowering of the jib.



Jib Telescope

Provides extension and retraction of the jib.



Machine Safety System Override (MSSO) (If Equipped)

Provides emergency override of function controls that are locked out in the event of Load Sense System activation.



Main Boom Lift

Provides raising and lowering of the main boom.



Main Boom Telescope

Provides extension and retraction of the main boom.



Platform Leveling Override Switch

A three position switch allows the operator to adjust the automatic self leveling system. This switch is used to adjust platform level in situations such as ascending/descending a grade.



! WARNING

Only use the platform leveling override function for slight leveling of the platform. Incorrect use could cause the load/occupant to shift or fall. Failure to do so could result in death or serious injury.

Platform Rotate

Provides rotation of the platform.



Platform / Ground Select Switch

The three position, key operated switch supplies power to the platform control console when positioned to Platform. With the switch key turned to the Ground position only ground controls are operable.



Note: When the Platform/Ground Select Switch is in the center position, power is shut off to the controls at both operating stations. Remove the key to prevent the controls from being actuated.



Power / Emergency Stop Switch

A two-position red mushroom shaped switch supplies power to Platform/Ground Select switch when pulled out (On position). When pushed in (Off position), power is shut off to the Platform/Ground Select switch.



Note: When Power/Emergency Stop switch is in the On position and engine is not running, an alarm will sound, indicating the ignition is On.

NOTICE

Always position emergency stop switch to the Off position (pushed in) when machine is not in use.

Swing

Provides 360 degrees continuous turntable rotation.



3.4 GROUND CONTROL INDICATOR PANEL

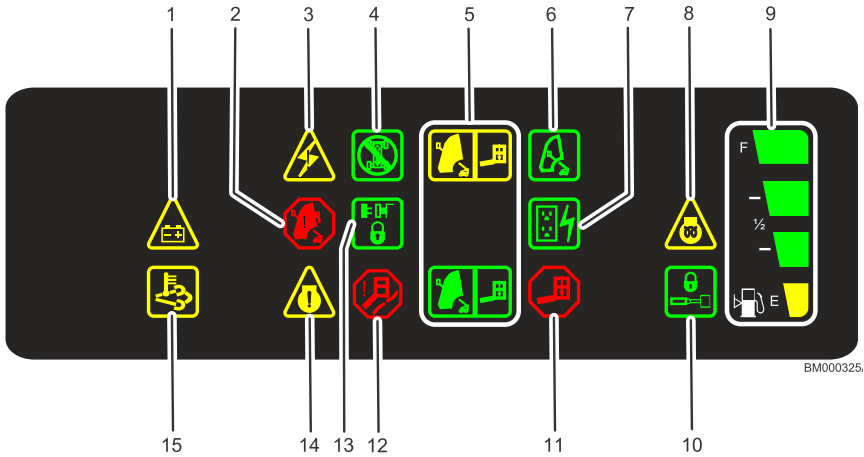

BM000325.

- | | |
|-----------------------------------|---------------------------|
| 1. Battery Charge | 10. Jib Lock Indicator |
| 2. Boom Control System Warning | 11. Platform Overload |
| 3. System Distress | 12. Wire Rope Service |
| 4. Drive and Steer Disable | 13. Axles Set |
| 5. Capacity Zone Indicator | 14. Engine Error |
| 6. Boom Control System Calibrated | 15. Emissions Temperature |
| 7. AC Generator | |
| 8. Glow Plug | |
| 9. Fuel Gauge | |

3.4.1 Ground Control Indicator Panel Functions

AC Generator

Indicates the generator is in operation.



Axles Set

Indicates the axles are fully extended. The indicator will flash as the axles are extending or retracting and be solid when fully extended. The indicator icon will go out when the axles are fully retracted.



Battery Charge

Indicates a problem in the battery or charging circuit, and service is required.



Boom Control System Calibrated

When illuminated, the light indicates the Boom Control System is properly calibrated.



Boom Control System Warning

Indicates the platform is outside the operating area and operation of certain boom functions may be disabled (i.e. lift, telescope). Attempts to use the disabled functions cause the indicator to flash and an alarm to sound. Immediately return the platform to the ground. If the indicator remains lit a boom control system fault or failure has been detected. If a failure is discovered, the system must be repaired by a JLG factory trained technician before the machine can be used.



Capacity Zone Indicator

Indicates the platform capacity zone for the current position of the platform. Restricted capacities are permitted at restricted platform positions (shorter boom lengths and higher boom angles).

Note: Refer to the capacity decals on the machine for restricted and unrestricted platform capacities.



Drive and Steer Disable

Indicates the Drive and Steer Disable function has been activated.



Emissions Temperature

Indicator illuminates when exhaust temperature reaches 1022° F (550° C).



Engine Error

Indicates a fault with the engine and service is required or is requesting a cleaning sequence.



Fuel Gauge

Indicates the level of the fuel in the fuel tank.



Glow Plug

Indicates the glow plugs are on. The glow plugs are automatically turned on with the ignition circuit and remain on for approximately seven seconds. Start the engine only after the light goes out.



Jib Lock Indicator

When illuminated indicates the jib lock pins are set in place.



Platform Overload

Indicates the platform has been overloaded.



System Distress

The light indicates that the JLG Control System has detected an abnormal condition and a Diagnostic Trouble Code has been set in the system memory. Refer to the Service Manual for instructions concerning the trouble codes and trouble code retrieval.



The system distress indicator light will illuminate for 2-3 seconds when the key is positioned to the ON position to act as a self test.

Wire Rope Service

When illuminated, the light indicates the wire ropes are loose or broken and must be repaired or adjusted prior to use.



3.5 PLATFORM CONTROL STATION

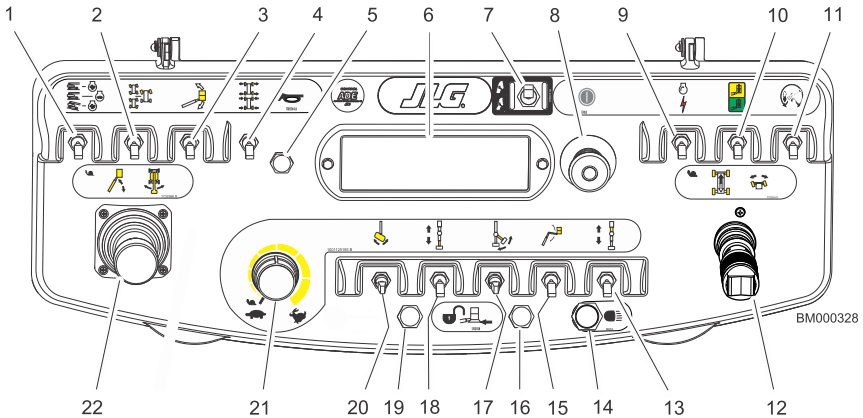

- | | |
|--------------------------------------|---|
| 1. Drive Speed / Torque Select | 13. Main Boom Telescope |
| 2. Steer Select | 14. Lights / SkySense Mute |
| 3. Platform Level Override | 15. Jib Lift |
| 4. Axle Extend / Retract | 16. Soft Touch / SkyGuard / SkySense Override |
| 5. Horn | 17. Jib Stow |
| 6. Indicator Panel | 18. Jib Telescope |
| 7. Boom Control Select (If Equipped) | 19. Soft Touch / SkyGuard Indicator |
| 8. Power / Emergency Stop | 20. Platform Rotate |
| 9. Engine Start / Auxiliary Power | 21. Function Speed Control |
| 10. Capacity Select | 22. Main Lift / Swing Controller |
| 11. Drive Orientation Override | |
| 12. Drive / Steer | |

3.5.1 Platform Control Station Functions

⚠ WARNING

To avoid serious injury, do not operate machine if any control levers or toggle switches controlling platform movement do not return to the off or neutral position when released.

⚠ WARNING

Only use the platform leveling override function for slight leveling of the platform. Incorrect use could cause the load/occupants to shift or fall. Failure to do so could result in death or serious injury.

Axle Extend / Retract

Allows the operator to extend or retract the axles. The axles can only be extended or retracted while the machine is being driven forward or reverse.



Boom Control Select

Automatic Mode:

When the Boom Control is positioned to Automatic, lift and telescope movements are coordinated by the JLG control system and the automatic platform leveling feature is active during lift, telescope, and drive movements.



Note:

- While operating lift up, the boom may also telescope out.
- While operating lift down, the boom may also telescope in.
- While operating swing or drive, the boom may lift up or lift down.
- While operating telescope in, the boom may lift down when at high boom angles and the creep light is flashing.

Manual Mode:

When the boom control is positioned to Manual, lift and telescope movements are controlled separately by the operator and the automatic platform leveling feature is active only during lift functions.



Note:

When positioned to Manual, boom functions will be stopped when the envelope limits are reached. When this occurs, operate a different function or select the automatic position.

Note:

Depending upon the angle of the chassis and the angle of the boom, swing left or swing right may not be allowed while in the Manual mode. The BCS light will illuminate and further attempts to swing in the not allowed direction will cause the BCS to flash. When this occurs the only choices are to swing in the opposite direction or switch to Automatic mode.

Capacity Select

This switch allows the operator to select between an operating envelope with a 500 lb (227 kg for ANSI markets and 230 kg for CE and Australia markets) capacity restriction or a 1000 lb (454 kg for ANSI markets and 450 kg for CE and Australia markets) capacity restriction.



Drive Orientation Override

When the boom is swung over the rear tires or further in either direction, the Drive Orientation indicator will illuminate when the drive function is selected. Push and release the switch, and within 3 seconds move the Drive/Steer control to activate drive or steer. Before driving, locate the black/white orientation arrows on both the chassis and the platform controls. Move the drive controls in a direction matching the directional arrows for the intended direction of travel.



Note: Lift, Swing, and Drive control levers are spring-loaded and will automatically return to neutral (off) position when released.

⚠ WARNING

To avoid serious injury, do not operate machine if any control levers or toggle switches controlling platform movement do not return to the off or neutral position when released.

Note: To operate the Drive joystick, pull up on the locking ring below the handle.

Note: The Drive joystick is spring loaded and will automatically return to neutral (off) position when released.



Drive Speed / Torque Select

The machine has a three position switch.

The forward position gives maximum drive speed. The center position allows the switch to energize the starter motor to start the engine. When pushed forward, the machine can be driven as quietly as possible. The back position gives maximum torque for rough terrain and climbing grades.



⚠ CAUTION

Do not operate machine if drive speed /torque select switch operates when boom is above horizontal.

Drive / Steer

Push forward to drive forward, pull back to drive in reverse. Steering is accomplished via a thumb-activated rocker switch on the end of the steer handle.



Engine Start / Auxiliary Power

When pushed forward, the switch energizes the starter motor to start the engine.

The Auxiliary Power control switch energizes the electrically operated hydraulic pump. (Switch must be held on for duration of auxiliary pump use.)



The auxiliary pump functions to provide sufficient oil flow to operate the basic machine functions should the main pump or engine fail. The auxiliary pump will operate tower boom lift, tower telescope, main boom lift, main telescope and swing.



Function Speed Control

This control affects the speed of the Main Boom Telescope, Jib Telescope, Jib Lift, Jib Swing, and Platform Rotate functions.



Note: During platform rotation, a speed difference may not be noticeable to the operator.

Turning the knob all the way counterclockwise until it clicks puts the machine into Creep Mode. Creep Mode puts the functions listed above, as well as the Drive/Steer and Main Lift/Swing functions into the slowest speed setting.

Note: To operate the Main Boom Lift/Swing joystick, pull up on the locking ring below the handle.



Note: The Main Boom Lift/Swing joystick is spring loaded and will automatically return to neutral (Off) position when released.

 **CAUTION**

Do not operate machine if function speed switch operates when boom is above horizontal.

Horn

A push-type Horn switch supplies electrical power to an audible warning device when pressed.



Jib Lift

Provides raising and lowering of the jib.



Jib Stow

Allows the jib to be returned to the stowed position for transport and also taken out of the transport position for machine usage. This control operates both jib swing and the jib lock pin in a coordinated manner.



Jib Telescope

Provides extension and retraction of the jib.



Note: The Jib Telescope function only operates in the 500 lb. (227 kg for ANSI markets and 230 kg for CE/UKCA and Australia markets) capacity mode.

Lights / SkySense Mute (If Equipped)

This switch operates the accessory lights package if the machine is so equipped.



Note: The ignition switch does not have to be on to operate the lights, so care must be taken to avoid draining the battery if left unattended. The master switch and/or the ignition switch at the ground control will turn off power to all lights.

If machine is equipped with SkySense, the switch will mute the SkySense speakers.



Main Boom Telescope

Provides extension and retraction of the main boom.



Main Lift / Swing Controller

Provides main lift and swing. Push forward to lift up, pull backward to boom down. Move right to swing right, move left to swing left.



Platform Level Override

A three position switch allows the operator to adjust the automatic self leveling system. This switch is used to adjust platform level in situations such as ascending/descending a grade.



Platform Rotate

Provides rotation of the platform.



Power / Emergency Stop

A two-position red mushroom shaped switch furnishes power to Platform Controls when pulled out (On). When pushed in (Off), power is shut off to the platform functions.



Soft Touch / SkyGuard / SkySense Indicator

Indicates the Soft Touch bumper is against an object or the SkyGuard sensor has been activated. All controls are cut out until the override button is pushed. For Soft Touch, controls are then active in the Creep Mode or for SkyGuard, controls will work normally.

If machine is equipped with SkySense, the switch will mute the SkySense speakers.

Soft Touch / SkyGuard / SkySense Override

For machines equipped with SkyGuard:

The SkyGuard override switch enables functions cut out by the SkyGuard system to be operated again, allowing the operator to resume use of machine functions.



For machines equipped with both SkyGuard and Soft Touch:

The switch operates like the SkyGuard override switch as described above. The switch also enables the functions cut out by the Soft Touch system to operate again at creep speed, allowing the operator to move the platform away from the obstacle that caused the shutdown situation.



For machines equipped with both SkyGuard and SkySense:

The switch operates like the SkyGuard override switch as described above. The switch also enables the functions cut out by the SkySense system to operate again at creep speed, allowing the operator to move the platform closer to the obstacle that caused the shutdown situation if desired.



Steer Select

The action of the steering system is operator selectable. The center switch position gives conventional front wheel steering with the rear wheels unaffected. This is for normal driving at maximum speeds. The forward position is for “crab” steering. When in this mode both front and rear axles steer in the same direction, which allows the chassis to move sideways as it goes forward. This can be used for positioning the machine in aisle ways or close to buildings. The back switch position is for “coordinated” steering. In this mode the front and rear axles steer in the opposite directions to produce the tightest turning circle for maneuvering in confined areas.



3.6 PLATFORM CONTROL INDICATOR PANEL

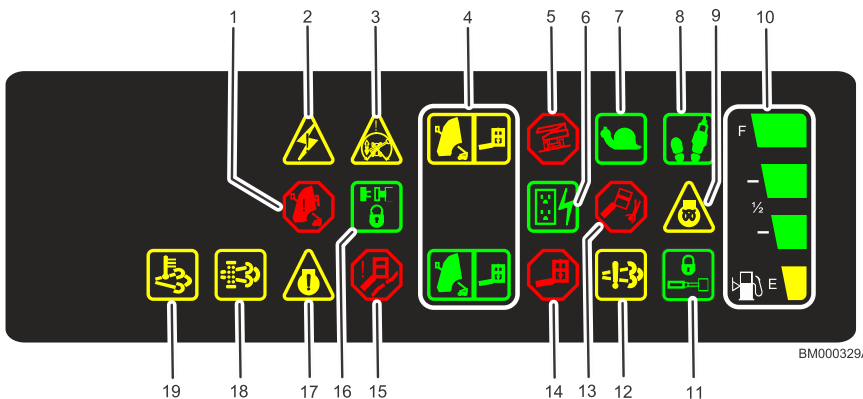

BM000329.

- | | |
|--------------------------------|-------------------------------|
| 1. Boom Control System Warning | 11. Jib Lock Indicator |
| 2. System Distress | 12. Emissions Failure |
| 3. Drive Orientation | 13. Level System |
| 4. Capacity Zone Indicator | 14. Platform Overload |
| 5. Tilt Alarm / Warning | 15. Wire Rope Service |
| 6. AC Generator | 16. Axles Set |
| 7. Creep Speed | 17. Engine Error |
| 8. Footswitch Enable | 18. Diesel Particulate Filter |
| 9. Glow Plug | 19. Emissions Temperature |
| 10. Fuel Gauge | |

3.6.1 Platform Control Indicator Panel Functions

AC Generator

Indicates the generator is in operation.



Axles Set

Indicates the axles are fully extended. The indicator will flash as the axles are extending or retracting and be solid when fully extended. The indicator icon will go out when the axles are fully retracted.



Boom Control System Warning

Indicates the platform is outside the operating area and operation of certain boom functions may be disabled (i.e. lift, telescope). Attempts to use the disabled functions cause the indicator to flash and an alarm to sound. Immediately return the platform to the ground. If the indicator remains lit a boom control system fault or failure has been detected. If a failure is discovered, the system must be repaired by a JLG factory trained technician before the machine can be used.



Capacity Zone Indicator

Indicates the platform capacity zone for the current position of the platform. Restricted capacities are permitted at restricted platform positions (shorter boom lengths and higher boom angles).



Note: Refer to the capacity decals on the machine for restricted and unrestricted platform capacities.

Creep Speed

When the Function Speed Control is turned to the creep position, the indicator acts as a reminder that all functions are set to the slowest speed.



Diesel Particulate Filter

Icon will illuminate when standstill exhaust system cleaning is required.



Drive Orientation

When the boom is swung beyond the rear drive tires or further in either direction, the Drive Orientation indicator will illuminate when the drive function is selected. This is a signal for the operator to verify that the drive control is being operated in the proper direction (i.e. controls reversed situations).



Emissions Temperature

Icon illuminates when the engine emissions control sensor reaches a high temperature.



Engine Emissions System Failure

Icon illuminates when there is a fault with the Emissions After Treatment system.



Engine Error

Indicates a fault with the engine and service is required.



Footswitch Enable

To operate any function, the footswitch must be pressed down and the function selected within seven seconds. The enable indicator shows that the controls are enabled. If a function is not selected within seven seconds, or if a seven second lapse between ending one function and beginning the next function, the enable light will go out and the footswitch must be released and pressed again to enable the controls.



Releasing the footswitch removes power from all controls and applies the drive brakes.

WARNING

To avoid serious injury, do not remove, modify or disable the footswitch by blocking or any other means.

Fuel Gauge

Indicates the level of the fuel in the fuel tank.



Glow Plug

Indicates the glow plugs are operating. After turning on ignition, wait until light goes out before cranking engine.



Jib Lock Indicator

When illuminated indicates the jib lock pins are set in place.



Level System

Indicates a fault in the electronic leveling system. The fault indicator will flash and an alarm will sound. All functions will default to creep if the boom is extended past transport mode or elevated more than 8 degrees above horizontal.



Platform Overload

Indicates the platform has been overloaded.



System Distress

The light indicates that the JLG Control System has detected an abnormal condition and a Diagnostic Trouble Code has been set in the system memory. Refer to the Service Manual for instructions concerning the trouble codes and trouble code retrieval.



Tilt Warning Light and Alarm

This red illuminator indicates that the chassis is on a slope. If the boom is above horizontal and the machine is on a slope, the tilt alarm warning light will illuminate, an alarm will sound, available functions are placed in Creep speed, and drive is cut out in direction of travel. Drive in the opposite direction may be allowed under certain conditions.



Note: When the tilt sensor alarm is activated, the Drive function will be disabled if the boom is elevated above horizontal.

WARNING

If Tilt Warning Light Is Illuminated When Boom Is Raised Or Extended, Retract And Lower To Below Horizontal Then Reposition Machine So That It Is Within The Limits Of The Maximum Operating Slope Before Extending Boom Or Raising Boom Above Horizontal.

Tilt Angle	Market
4°	All Markets

Wire Rope Service

When illuminated, the light indicates the wire ropes are loose or broken and must be repaired or adjusted prior to use.



SECTION 4

Machine Operation

4.1 DESCRIPTION

This machine is a mobile elevating work platform used to position personnel, along with their necessary tools and materials at work locations.

The primary operator control station is in the platform. From this control station, the operator can drive and steer the machine in both forward and reverse directions. The operator can raise or lower the upper or lower boom or swing the boom to the left or right. Standard boom swing is 360° non-continuous left and right of the stowed position. The machine has a Ground Control Station which will override the Platform Control Station. Ground Controls operate all functions except drive and steer. Except for performing inspections and the Function Check, the ground controls are used in an emergency to lower the platform to the ground should the operator in the platform be unable to do so.

4.2 OPERATING CHARACTERISTICS AND LIMITATIONS

4.2.1 Capacities

The boom can be raised more than 15° above horizontal with or without any load in platform, if:

1. Machine is positioned on a smooth, firm surface within the limits of the maximum operating slope.
2. Axles are extended.
3. Jib is centered and lock pin is engaged.
4. Load is within manufacturer's rated capacity.
5. All machine systems are functioning properly.
6. Machine is as originally equipped from JLG.

4.2.2 Controlled Arc

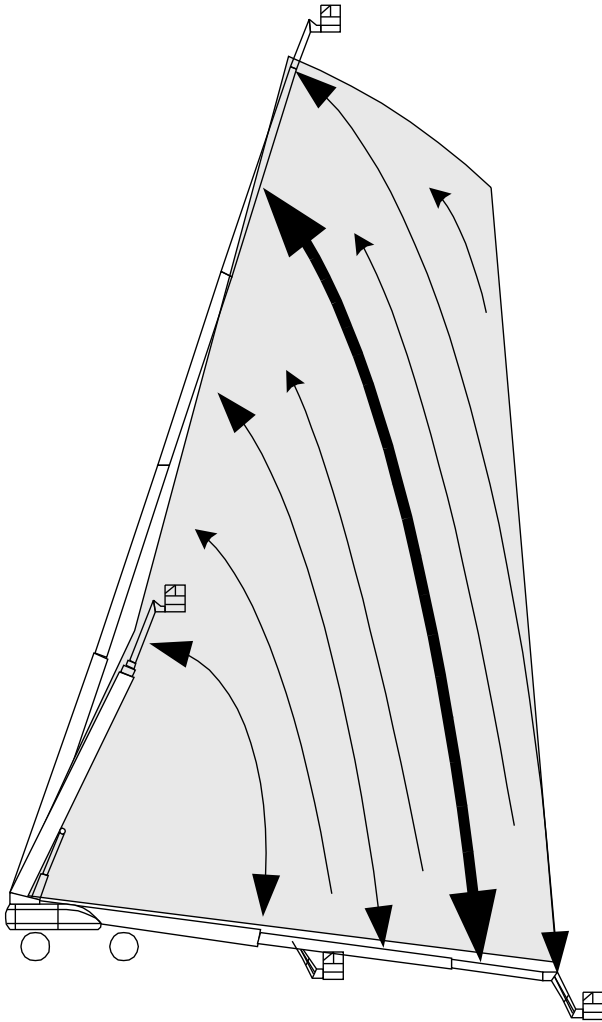

BM000314

When the Boom Control Select switch is in the automatic mode, the boom control system automatically controls lift and telescope when the lift function is selected to move the platform through a predetermined arc, equivalent to the percentage of extension. (i.e. If you start at 70% boom extension, you will end up at approximately 70% boom extension no matter where you stop in the arc). This means that when lifting down, telescope in will function automatically, or when lifting up, telescope out will function automatically.

When the Boom Control Switch is in the manual mode, lift and telescope functions are independent functions controlled by the operator.

4.2.3 Envelope Tracking

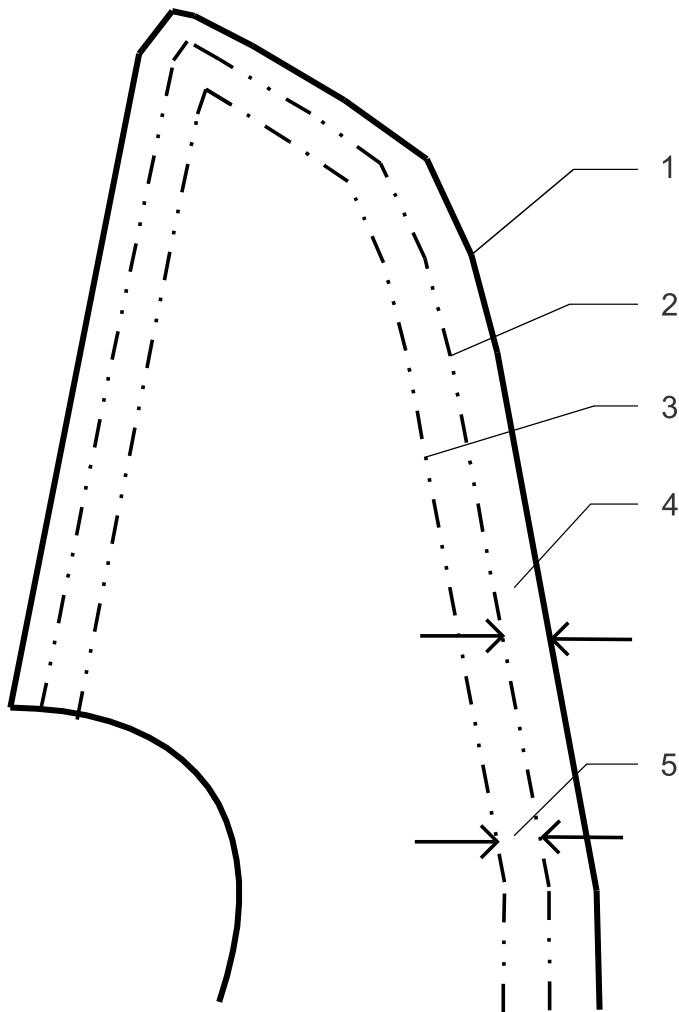

BM000315.

1. Envelope
2. Buffer Line
3. Slow Down Zone

4. Buffer Zone
5. Slow Down Zone

When the platform approaches the edges of the operating envelope all machine functions are slowed down automatically by the boom control system to reduce machine motions.

Note: Boom Control System in Automatic Mode: When the boom is completely elevated along the edge of the backward stability region and the telescope in function is activated, lift down will automatically function until the boom is away from the edge of the backward stability region.
Boom Control System in Manual Mode: The boom will stop when the end of the envelope is reached and the operator must activate lift and/or telescope in the proper direction to bring the boom back into the envelope.

4.2.4 Controlled Angle

The control system automatically maintains a constant elevated boom angle when swinging the turntable. If the boom angle is at 30 degrees, swing engaged by its self shall add lift to maintain the relative boom angle at 30 degrees.

4.2.5 Swing Speed Proportioning

The boom control system sensors sense the distance the platform is extended from the turntable, allowing higher swing speeds with the boom retracted and gradually slower swing speeds as the boom is extended.

4.2.6 Platform Load Sensing System (LSS)

The Platform Load Sensing System provides the platform load to the control system.

If the LSS system senses an overload condition, boom functions will be disabled, the overload indicator is illuminated at both control stations, and the overload alarm will sound. Reduce the weight in the platform to not exceed the rated workload indicated on the capacity decal, then the controls will work again.

4.3 STABILITY

Machine stability is based on two (2) conditions which are called Forward and Backward stability. The machine's position of least Forward stability is shown in (See [Figure — Position of Least Forward Stability](#)) and its position of least Backward stability is shown in (See [Figure — Position of Least Backward Stability](#))

⚠ WARNING

To avoid forward or backward tipping, do not overload machine or operate the machine beyond the limit of the maximum operating slope.

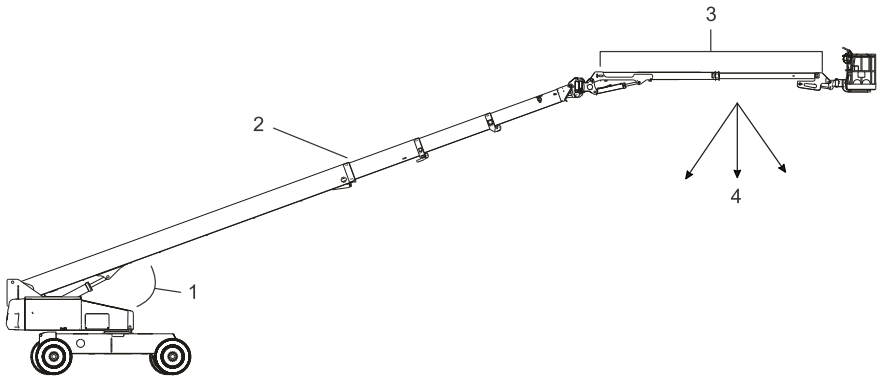
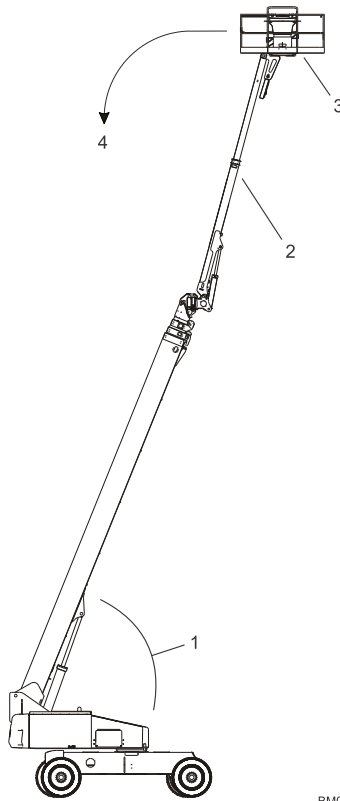

Figure 3. Position of Least Forward Stability

BM00033:

1. Main boom elevated 20°.
2. Main boom fully elevated.
3. Jib horizontal and fully extended.
4. Machine will tip over in the direction if overloaded or operated beyond the limits of the maximum operating slope.



BM000341

Figure 4. Position of Least Backward Stability

1. Main boom retracted and elevated 68°.
2. Jib fully extended.
3. Platform rotated 90°.
4. Machine will tip over in the direction if overloaded or operated beyond the limits of the maximum operating slope.

4.4 ENGINE OPERATION

- Note:** When operating a machine at high altitudes, a decrease in machine performance may occur due to a decrease in air density.
- Note:** When operating a machine at high ambient temperatures, a decrease in machine performance and an increase in engine coolant temperature may occur.
- Note:** Avoid repeated, low intensity, or periodic machine operation and extended engine idle times in cold weather environments.

CAUTION

For every 8 hours of low intensity machine operation or extended engine idle time, drive the machine continuously for 15 minutes.

- Note:** Contact JLG Customer Service for operation under abnormal conditions.

4.4.1 Starting Procedure

- Note:** Initial starting should always be performed from the Ground Control station. Make sure to perform a ground control function check prior to platform operation.

! CAUTION

If engine fails to start promptly, do not crank for an extended time. Should engine fail to start again, allow starter to cool off for 2-3 minutes. If engine fails after several attempts, refer to engine maintenance manual.

Note: Diesel engines only: After turning on ignition power, operator must wait until glow plug indicator light goes out before cranking engine.



1. Turn key of Platform/Ground Select switch to Ground.



2. Pull the Power/Emergency Stop switch to On.



3. Push the Engine Start switch until engine starts.



! CAUTION

Allow engine to warm-up for a few minutes at low speed before applying any load.

4. After engine has had sufficient time to warm up, push in the Power/Emergency Stop switch and shut engine off.



5. Turn Platform/Ground Select switch to Platform.



6. From Ground Control Console, pull Power/ Emergency Stop switch out.



- From Platform, pull Power/Emergency Stop switch out.



- Push the Engine Start switch until engine starts.



Note: Footswitch must be released in the up position before starter will operate. If starter operates with footswitch in the down position, do not operate the machine.

4.4.2 Shutdown Procedure

CAUTION

If an engine malfunction causes an unscheduled shutdown, determine the cause and correct it before restarting the engine.

- Remove all load and allow engine to operate at low speed for 3-5 minutes; this allows further reduction of internal engine temperature.
- Push Power/Emergency Stop switch in.



- Turn Platform/Ground Select switch to Off.



Note: Refer to Engine Manufacturer's manual for detailed information.

4.5 AIR SHUTOFF VALVE (ASOV) (IF EQUIPPED)

Air Shutoff Valve (ASOV) is an overspeed protection device mounted to the engine's air intake system. When the valve is actuated, it obstructs airflow intake and stops the engine. Weekly tests are recommended to ensure the valve remains in good working condition.

1. Start the engine, running at idle.
2. Open the red switch guard on ASOV test switch, then activate toggle to test mode.

Note: Test switch is located under hood to the left of the ground control panel (look for test decal).



3. At the ground control panel, select any function and activate until valve actuates at test RPM of 1500. Once valve actuates, engine will stop.
4. Turn ignition power OFF.
5. Visually inspect valve to ensure it appears in good condition.
6. Reset valve by rotating valve handle to the Open position.

Note: The handle cannot be turned unless the machine is off. Ensure the ignition power is OFF.

⚠ WARNING

Do not use ASOV as an alternative to shutting down machine properly.

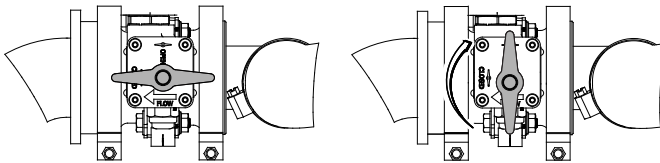

Figure 5. ASOV Reset (Closed to Open Position)

4.6 FUEL SHUTOFF SYSTEM (RESERVE)

Note: Reference the Service and Maintenance Manual along with a qualified JLG Mechanic to verify your machine setup.

The Fuel Shutoff System monitors the fuel in the tank and senses when the fuel level is getting low. The JLG Control System automatically shuts the engine down before the fuel tank is emptied unless the machine is set up for Engine Restart.

If fuel level reaches the Low Fuel range the $\frac{1}{4}$ tank indicator will flash once a second and there will be approximately 5 minutes of engine run time left. If the system is in this condition and automatically shuts down the engine, or the engine is manually shut down before the 5 minute run time is complete, the $\frac{1}{4}$ tank indicator will flash 10 times a second and the engine will react according to machine setup. Setup options are as follows:

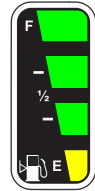

- **Engine One Restart** - When the engine shuts down, the operator will be permitted to cycle power and restart the engine once with approximately 2 minutes of run time. After the 2 minute run time is complete or if the engine is shut down by the operator prior to the completion of the 2 minute run time, it cannot be restarted until fuel is added to the tank.
- **Engine Restart** - When the engine shuts down, the operator will be permitted to cycle power and restart the engine for approximately 2 minutes of run time. After the 2 minutes of run time is complete, the operator may cycle power and restart the engine for an additional 2 minutes of run time. The operator can repeat this process until there is no more fuel available.

NOTICE

Contact a qualified JLG mechanic if the machine needs restarted after no more fuel is available.

- **Engine Stop** - The engine will shut down. No restarts will be permitted until fuel is added to the tank.

4.7 CAPACITY SELECT

This machine is equipped with a Dual Capacity System which allows the operator to select operation in unrestricted and restricted capacity zones by positioning the Capacity Select switch on the platform console. The applicable capacity zone indicator will light in both the platform control and the ground control stations based on the position of the Capacity Select switch.



When platform load is equal to or less than 500 lb (227 kg for ANSI markets and 230 kg for CE, UKCA, and Australia markets), the platform is unrestricted within the full machine envelope boundary. When the platform load is between 500 lb (227 kg for ANSI markets and 230 kg for CE, UKCA, and Australia markets) and 1000 lb (454 kg for ANSI markets and 450 kg for CE, UKCA, and Australia markets), the platform position is restricted within a smaller working envelope boundary.

The machine will stop at the boundary from the restricted to the unrestricted zone unless the Capacity Select switch is in the unrestricted position. Both capacity lights will flash and an alarm will sound if the platform is out of the selected capacity range.

Note: Operation in the 1000 lb (454 kg for ANSI markets and 450 kg for CE, UKCA, and Australia markets) envelope requires the jib to be fully retracted.

4.8 DIESEL PARTICULATE FILTER (IF EQUIPPED)

Diesel Particulate Filter (DPF) is an emissions control system used in diesel engines and requires operator interaction to ensure proper operation of the system.

For peak operation, the DPF system must be cleaned using one of two methods, Standstill Cleaning and Maintenance Standstill Cleaning. Standstill Cleaning is any cleaning requested by the engine outside of the regular maintenance window (for example, if the system detects excessive soot in the DPF canister). Maintenance Standstill Cleaning is cleaning requested by the engine on the regular maintenance interval.

Note: The system will reset the maintenance interval back to zero hours after Standstill or Maintenance Standstill Cleaning events are performed.

Note: For Standstill Cleaning procedures, please refer to the Service & Maintenance manual associated with this model.

4.9 TRAVELING (DRIVING)

Note: When the main boom is raised approximately 3° above horizontal, the high drive function will automatically be in low drive.

⚠ WARNING

Do not drive with boom above horizontal except on a smooth, firm surface within the limits of the maximum operating slope.

Be sure the turntable lock is engaged before any extended traveling.

⚠ WARNING

Do not drive on side slopes which exceed 5 degrees.

To avoid loss of travel control or tip over, do not drive machine on grades exceeding those specified in the operating specifications section of this manual.

⚠ WARNING

Use extreme caution when driving in reverse and at all times when the platform is elevated.

Before driving, locate the black/white orientation arrows on both the chassis and the platform controls. Move the drive controls in a direction matching the directional arrows for the intended direction of travel.

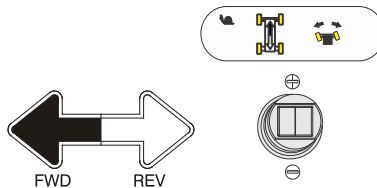

4.9.1 Traveling Forward and Reverse

1. At Platform Controls, pull out Emergency Stop switch, start engine, and activate footswitch.
2. Position Drive controller to Forward or Reverse as desired.

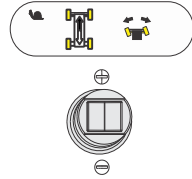

This machine is equipped with a Drive Orientation Indicator. The yellow light on the platform control console indicates that the boom is swung beyond the rear drive tires and the machine may Drive/Steer in the opposite direction from the movement of the controls. If the indicator is illuminated, operate the Drive function in the following manner:

1. Match the black and white direction arrows on both platform control panel and the chassis to determine the direction the machine will travel.
2. Push and release the Drive Orientation Override switch. Within 3 seconds, slowly move the Drive control toward the arrow matching the intended direction of machine travel. The indicator light will flash during the 3 second interval until the drive function is selected.

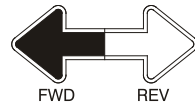

4.10 TRAVELING (GRADE/SIDE SLOPE)

4.10.1 Traveling on a Grade

When traveling a grade, maximum braking and traction are obtained with the boom stowed, in position over the rear (drive) axle, and in line with the direction of travel. Drive the machine forward when climbing a grade and in reverse when descending a grade. Do not exceed the machine's maximum rated gradeability.

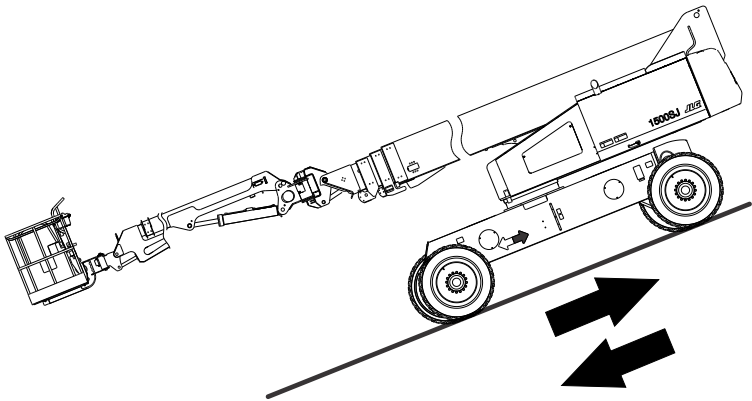

BM00034

Figure 6. Traveling on a Grade

NOTICE

If the boom is over the front (steer) axle, direction of steer and drive movement will be opposite from the movement of the controls.

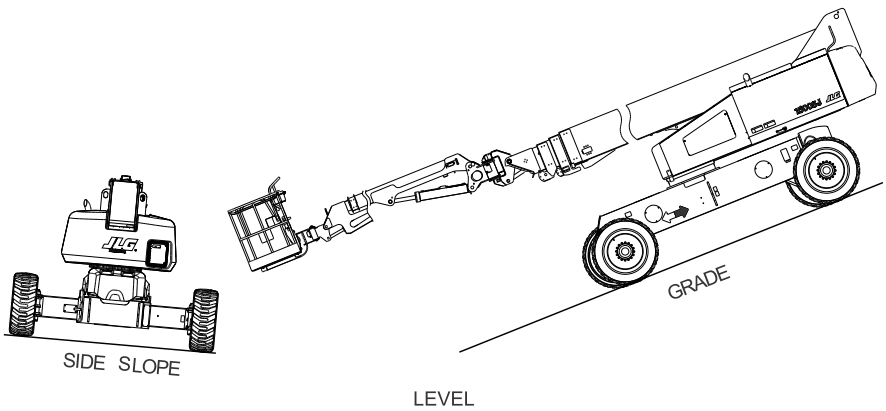

BM00034

Figure 7. Grade and Side Slope

4.11 STEERING

Press footswitch. Position thumb switch on Drive/Steer controller to Right for steering right, or to Left for steering left.



4.12 EXTENDING THE AXLES

Note: The operator must be driving the machine (forward or reverse) in order to extend the axles.

Position the Axle Extend switch to extend or retract the axles.

4.13 PLATFORM

4.13.1 Platform Level Adjustment

! WARNING

Only use the platform leveling override function for slight leveling of the platform. Incorrect use could cause the load/occupants to shift or fall. Failure to do so could result in death or serious injury.

Note: When the Boom Control Select Switch is in the Manual mode, Platform leveling only functions during Main Lift operation. When the Boom Control Select Switch is in the Automatic mode, Platform Leveling is active during all functions except during telescope operation. Also, when in the Manual mode, the Controlled Arc and Controlled Angle systems are not active.

During normal operation of the machine, the platform will automatically maintain its position.

To manually level Up or Down - Position the Platform/Level control switch Up or Down and hold until the desired platform position is obtained.



Note: Platform Leveling is active during all functions except during main boom telescope operations.

4.13.2 Platform Rotation

To rotate the platform to the left or right, use the Platform Rotate control switch to select the direction and hold until the desired position is reached.



4.14 BOOM

! WARNING

A red tilt warning light is located on the control console which lights when the chassis is on an excessive slope. Do not swing or raise boom above horizontal when indicator is lit.

Do not depend on the tilt warning light as a level indicator for the chassis. The tilt warning light indicates chassis is on an excessive slope (5 degrees or greater). Chassis must be level before swinging or raising boom above horizontal or driving with the boom elevated.

⚠ WARNING

To avoid tip over, if red tilt warning light illuminates when the boom is raised above horizontal, lower platform to ground level. Then reposition machine so that chassis is level before raising boom.

If the platform does not stop when a control switch or lever is released, remove foot from footswitch or use emergency stop switch to stop the machine.

⚠ WARNING

Traveling with the boom below horizontal is permitted on grades and side slopes specified in the Operating Specifications section of this manual.

⚠ WARNING

To avoid serious injury, do not operate machine if any control lever or toggle switch controlling platform movement does not return to the off or neutral position when released.

⚠ CAUTION

To avoid a collision and injury if platform does not stop when a control switch or lever is released, remove foot from footswitch or use emergency stop switch to stop the machine.

4.14.1 Swinging the Boom

Note: The axles must be fully extended to swing beyond the rear wheels (40 degrees).

To swing boom, use Swing control switch to select Right or Left direction.



NOTICE

When swinging the boom make sure there is ample room for the boom to clear surrounding walls, partitions and equipment.

4.14.2 Raising and Lowering the Main Boom

Note: The main lift function is not operable above 6 degrees above horizontal if the axles are not fully extended.

To raise or lower the Main Boom, position the Main Boom Lift switch to Up or Down until the desired height is reached.



4.14.3 Telescoping the Main Boom

Note: The telescope function is not operable beyond the transport position if the axles are not fully extended.

To extend or retract the main boom, use the Main Telescope Control Switch to select In or Out movement.

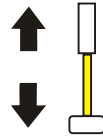

4.14.4 Telescoping the Jib

To extend or retract the jib, use the Jib Telescope Control Switch to select In or Out movement.

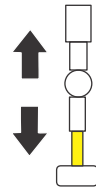

4.14.5 Stowing / Swinging the Jib

To swing the jib for stowage or machine usage, use the Jib Stow control to select Right or Left direction. The jib lock pin will also operate automatically while using the Jib Stow Switch.



4.15 FUNCTION SPEED CONTROL

This control affects the speed of Main Boom Telescope, Jib Telescope, Jib Lift, Jib Stow, and Platform Rotate functions.

Note: During platform rotation, a speed difference may not be noticeable to the operator.



Turning the knob all the way counterclockwise until it clicks puts the machine into Creep Mode. Creep Mode puts the functions listed above, as well as the Drive/Steer and Main Lift/Swing functions into the slowest speed setting.

4.16 USB CHARGING PORT

The machine is equipped with a USB charging port for the operator.

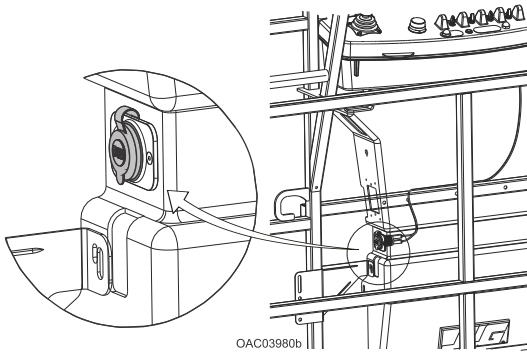

OAC03980b

4.17 MACHINE SAFETY SYSTEM OVERRIDE (MSSO) (IF EQUIPPED)

The Machine Safety System Override (MSSO) is used to override function controls for Emergency Platform Retrieval only. Refer to Emergency Procedures Section for Machine Safety System Override operating procedures (if equipped).



4.18 SKYGUARD OPERATION

SkyGuard provides enhanced control panel protection. When the SkyGuard sensor is activated, functions in use at the time of actuation will reverse or cutout. The SkyGuard Function Table provides more details on these functions.

During activation, the horn will sound and the SkyGuard beacon (if equipped) will illuminate until sensor and footswitch are disengaged.

If the SkyGuard sensor remains activated after function reversal or cutout, press and hold the SkyGuard Override Switch to allow normal functions until the sensor is disengaged.

Consult the following illustrations to determine which type of SkyGuard the machine has and how it is activated. Regardless of type, SkyGuard function according to the SkyGuard Function Table does not change.

4.18.1 SkyGuard

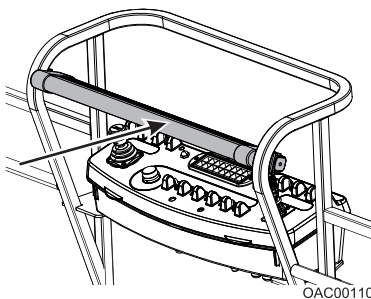

Approximately 50 lb (222 Nm) of force is applied to yellow bar.

4.18.2 SkyGuard - SkyLine

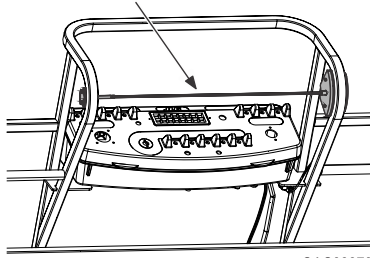

OAC03970

Rod is pressed, breaking the connection between the rod and right bracket.

4.18.3 SkyGuard - SkyEye

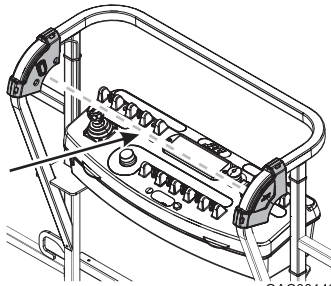

OAC00140

Operator passes through path of sensor beam.

4.18.4 SkyGuard Function Table

Drive Forward	Drive Reverse	Steer	Swing	Boom Lift Up	Boom Lift Down	Boom Tele Out	Boom Tele In	Jib Lift	Basket Level	Basket Rotate
R * / C **	R	C	R	R	R	R	C	C	C	C
R = Indicates Reversal is Activated										
C = Indicates Cutout is Activated										
* DOS (Drive Orientation System) Enabled										
** DOS Not Enabled, machine is driving straight without steering, and any other hydraulic function is active										
Note: If SkyGuard is enabled with the Soft Touch system, functions will cut out instead of reversing.										

4.19 EMERGENCY TOWING

⚠ WARNING

Runaway vehicle/machine hazard. Machine has no towing brakes. Towing vehicle must be able to control machine at all times. On-highway towing not permitted. Failure to follow instructions could cause serious injury or death.

⚠ WARNING

Maximum towing speed 5 mph (8 km/h)

⚠ WARNING

Maximum towing grade 25%.

⚠ CAUTION

Do not tow machine with engine operating or drive hubs engaged.

1. Retract, lower and position boom in travel position; lock turntable.
2. Disconnect drive hubs (1) by inverting disconnect cap (2). The disconnect cap will be in the inverted position (3).

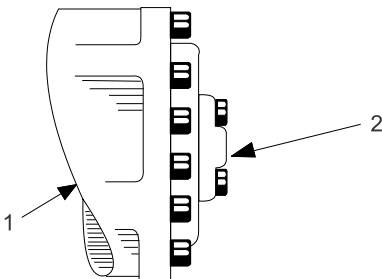

BM00028

Figure 8. Drive Hub Engaged

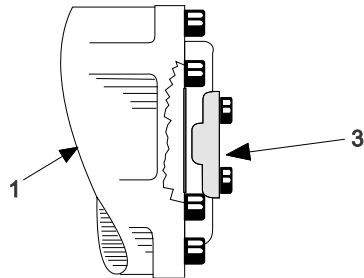

BM00028

Figure 9. Drive Hub Disengaged

3. Reconnect the drive hubs by inverting the disconnect cap when towing is complete.

4.20 SHUT DOWN AND PARK

The preferred procedures to shut down and park the machine are as follows:

1. Drive machine to a reasonably well protected area.
2. Ensure boom is fully retracted and lowered over rear axle.
3. Shut down Emergency Stop at Platform Controls.
4. Shut down Emergency Stop at Ground Controls. Position Platform/Ground Select switch to center OFF (center position).
5. If necessary, cover Platform Controls to protect instruction placards, warning decals, and operating controls from hostile environment.

NOTICE

If parking a MEWP with the boom elevated in an effort to conserve space, booms may be elevated, but shall not be extended. It is the operator's responsibility to ensure all safety precautions in Section 1 of this manual are followed for each unique situation.

4.21 LIFTING AND TIE DOWN

4.21.1 Lifting

1. Refer to the Machine Serial Number Plate, call JLG Industries, or weigh the individual unit to find out the Gross Vehicle Weight.
2. Place the boom in the stowed position.
3. Remove all loose items from the machine.
4. Properly adjust the rigging to prevent damage to the machine and so the machine remains level.

4.21.2 Tie Down

NOTICE

When transporting the machine, the boom must be fully lowered into the boom rest.

1. Place the boom in the stowed position.
2. Remove all loose items from the machine.
3. Secure the chassis using straps or chains of adequate strength.

Machine Operation

4. Ensure the platform is lowered so the wear pad on the bottom rests on the surface of the transportation vehicle.

Note: Secure through the tie downs on the boom using straps or chains of adequate strength.

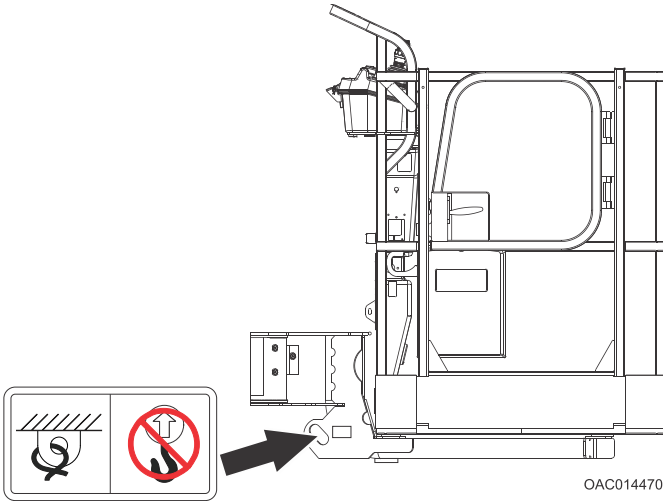

NOTICE

Secure turntable with turntable lock (if equipped) before traveling long distances or hauling machine on truck/trailer.

4.22 LIFTING CHART

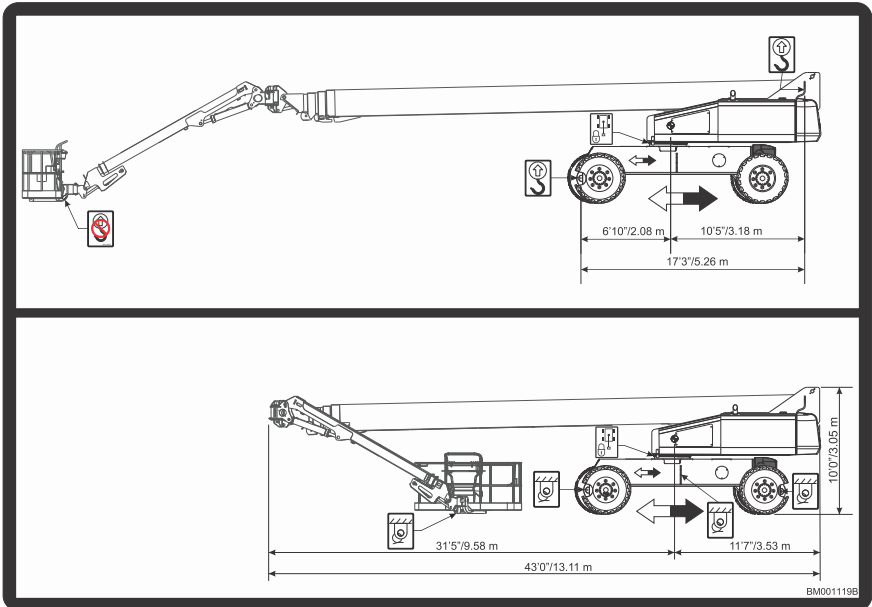

4.23 SAFETY DECALS

4.23.1 Safety Decal Locations and Legend

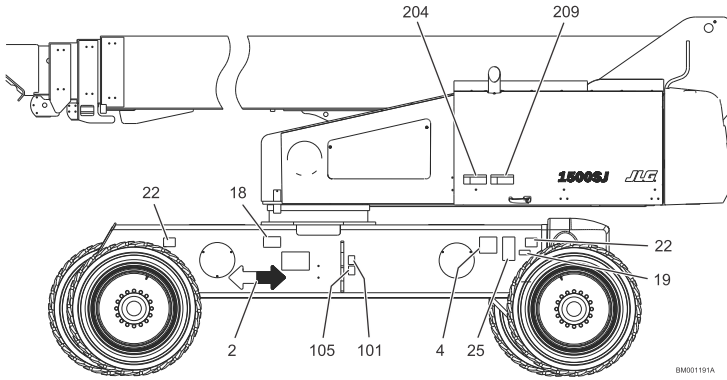

Figure 10. Decal Location Sheet 1 of 6

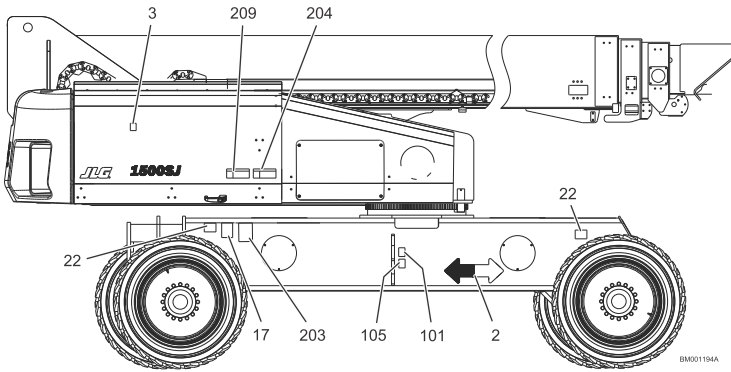

Figure 11. Decal Location Sheet 2 of 6

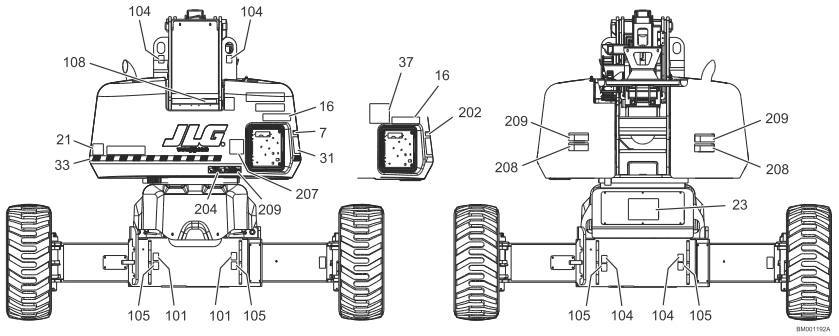

Figure 12. Decal Location Sheet 3 of 6

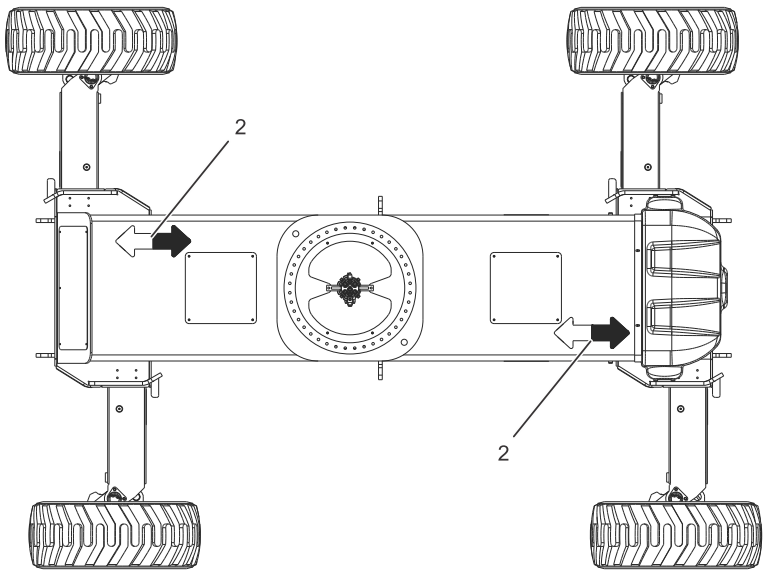

Figure 13. Decal Location Sheet 4 of 6

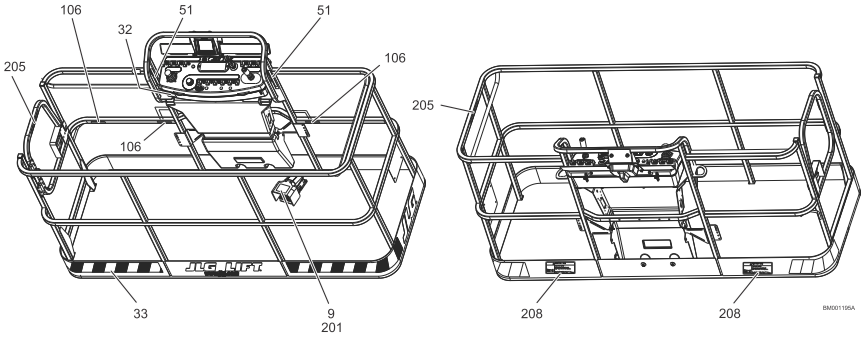

Figure 14. Decal Location Sheet 5 of 6

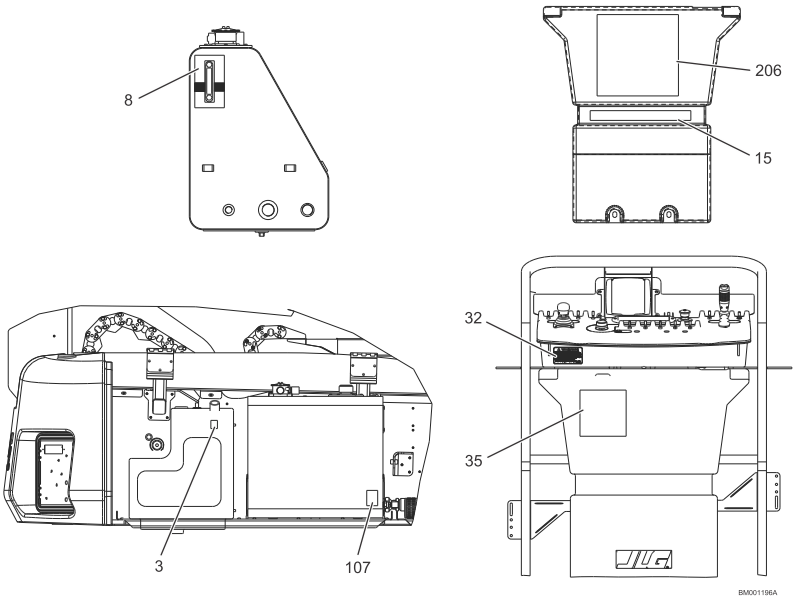

Figure 15. Decal Location Sheet 6 of 6

Table 4. Safety Decals Legend

Item #	ANSI	Korean	Chinese	Portuguese	Spanish	French	CE/UKCA	Japanese	Australian
2	1701501	1701501	1701501	1701501	1701501	1701501	1701501	1701501	1701501
3	1701505	1701505	1701505	1701505	1701505	1701505	1701505	1701505	1701505
5	1704972	1706061	1706060	1706059	1706063	1706064	1702773	1706062	1706098
6	1705351	1705427	1705430	1705905	1705910	1705429	1705174	1705426	1001125178
7	1705492	--	--	--	--	--	1705511	--	--
8	1705511	1705511	1705511	1705511	1705511	1705511	1705864	1705511	1705511
9	3252347	--	--	--	--	--	1706098	--	--
14	1001122611	1001122611	1001122611	1001122611	1001122611	1705174	1001125177	1001122611	1705174
15	1001253543	1001253547	1001253549	1001253551	1001253553	1001253545	1001125178	1001253555	1001125177
16	1001253544	1001253548	1001253550	1001253552	1001253554	1001253546	--	1001253556	--
17	1001131269	--	--	--	--	1001131269	--	--	--
18	1001223055	1001224048	1001224050	1001224052	1001224049	1001223971	--	1001221053	--
19	1001223453	--	--	--	--	--	--	--	--
22	1001225192	1001225192	1001225192	1001225192	1001225192	1001225192	1001225192	1001225192	1001225192
23	1001284692	1001284692	1001284692	1001284692	1001284692	1001284692	1001284692	1001284692	1001284692
31	1001125196	1001125197	1001125198	1001125200	1001125199	1001125201	1001125196	1001125202	1001125196
32	1001231801	--	--	--	--	--	--	--	--
33	4420051	4420051	4420051	4420051	4420051	4420051	4420051	4420051	4420051
34	--	--	--	--	--	--	1001197408	--	--

Table 4. Safety Decals Legend (continued)

Item #	ANSI	Korean	Chinese	Portuguese	Spanish	French	CE/UKCA	Japanese	Australian
35	--	--	--	--	--	--	1001177562	--	--
36	--	--	--	--	--	--	1705084 1001191525	--	1705084
37	--	--	--	--	--	--	--	--	1001112551
101	1701499	1701499	1701499	1701499	1701499	1701499	1701499	1701499	1701499
102	1701509	1701509	1701509	1701509	1701509	1701509	1701509	1701509	1701509
103	--	--	1701529	--	--	--	--	--	--
104	1703811	1703811	1703811	1703811	1703811	1703811	1703811	1703811	1703811
105	1703814	1703814	1703814	1703814	1703814	1703814	1703814	1703814	1703814
106	1704277	1704277	1704277	1704277	1704277	1704277	1704277	1704277	1704277
107	1704412	1704412	1704412	1704412	1704412	1704412	1704412	1704412	1704412
108	3251243	--	--	--	--	3251243	--	--	--
202	--	1705503	100117035	1705906	1705915	1705505	--	1705493	--
203	--	--	--	1705901	1704007	1704006	--	--	--
204	1703953	1703945	1703943	1705903	1703941	1703942	--	1703944	--
205	1702868	1705969	1001116846	1705967	1704001	1704000	--	--	--
206	1001231315	1001231317	1001231321	1001231319	1001231318	1001231316	1705921	1001231320	1705921
207	1705336	1705345	1001116849	1705896	1705917	1705347	1705822	1705344	1705822
208	1703804	1703951	1703949	1705898	1703947	1703948	1701518	1703950	1701518

Table 4. Safety Decals Legend (continued)

Item #	ANSI	Korean	Chinese	Portuguese	Spanish	French	CE/UKCA	Japanese	Australian
209	1703805	1703939	1001116851	1705897	1703935	1703936	1705961	1703938	1705961
210	--	1703981	1703982	1705902	1703983	1703984	1705828	1703980	1705828

This Page is intentionally left blank

SECTION 5

LCD Display Panel

5.1 DESCRIPTION

This machine utilizes an LCD display panel to assist the operator by supplying additional information during the operation of the machine. It is NOT a substitute for the Operation and Safety Manual, nor is it a replacement for thorough operational knowledge of the machine.

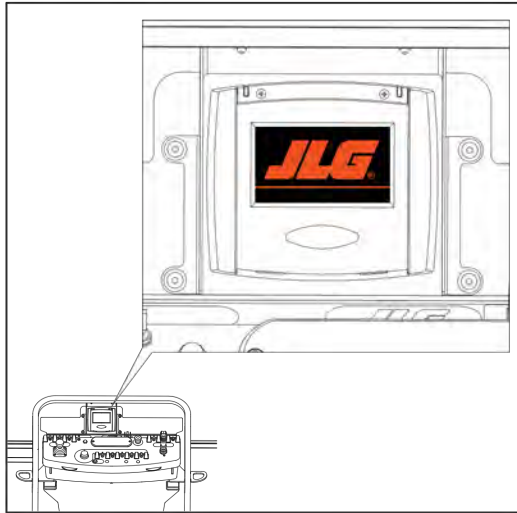

Figure 16. LCD Panel

5.2 BOOT UP SPLASH SCREEN

When the machine is first powered on, the JLG boot up splash screen appears followed by three reminder screens. There is a reminder for the operator to wear a full body harness with a lanyard attached to an authorized lanyard anchorage point, a reminder for the operator to read and understand the Operation and Safety Manual, and a reminder for the operator to select the desired capacity range of the machine. Each reminder screen will show for 3 seconds.



Figure 17. Boot Up Splash Screen

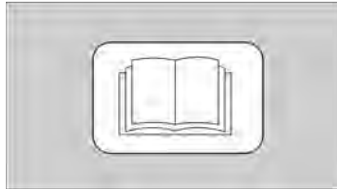

Figure 18. Manual Screen

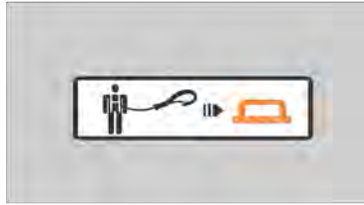

Figure 19. Lanyard Screen



Figure 20. Select Capacity Zone Screen

5.3 MACHINE OPERATING SCREEN

After the reminder screens, the Machine Operating Screen will appear. The Machine Operating Screen consists of different images and trays. Each tray provides different machine information.

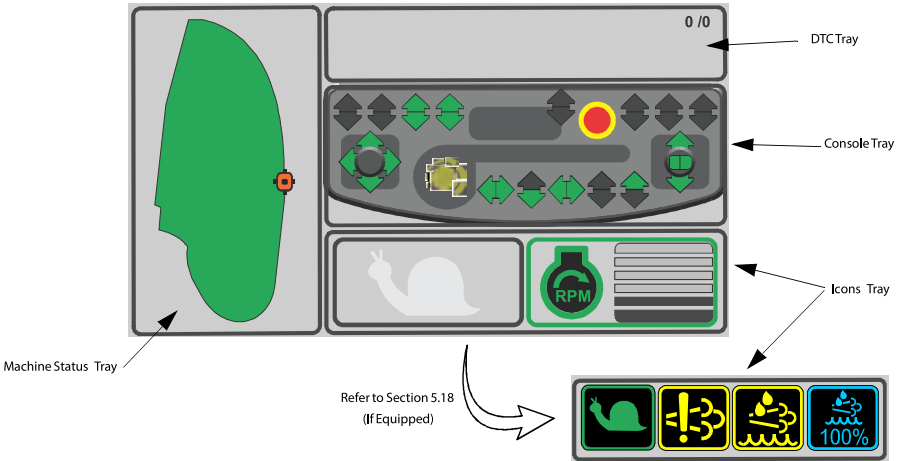

Figure 21. Machine Operating Screen

5.3.1 Diagnostic Trouble Code (DTC) Tray

This tray shows the total number of DTC's and the DTC Text. If there are multiple DTC's, the operator can scroll through the DTC List to the end. When the tray is empty, this means there are no active DTC's.

5.3.2 Console Tray

This tray represents the platform console information.

When the machine is in operation, and the footswitch is pressed, the console will show available functions with a green arrow and unavailable functions with a gray arrow.

Note: The green and gray console arrows shown in the examples in this section may be different depending upon machine setup and specific operating conditions.

5.3.3 Icons Tray

The Icons Tray shows engine RPM plus Creep and Super Creep modes.

The RPM level is represented in bars.

5.3.4 Machine Status Tray

The Machine Status Tray is used to display different images based on the machine status. These include:

- Key Switch Ground Mode
- CAN Bus Lost
- Take Foot Out
- Put Foot In
- BCS Lamp On
- Wire Rope Service
- System/Platform Level DTCs
- Platform Overload DTCs
- Weight Mode Error
- Chassis Status
- In Transport and Out of Transport
- Axles Extended, Retracted, Transient
- Machine Tilted
- Envelope Status
- Unknown Machine Model

5.4 KEYSWITCH IN GROUND MODE:

If the keyswitch is set to ground mode, the display shows the Key Switch in Ground Mode Image.



Figure 22. Keyswitch In Ground Mode Screen

5.5 FUNCTION SPEED

If there is no function speed restriction, a gray snail is shown. If the machine is in Creep Mode, a green snail icon is shown. If the machine is in Super Creep Mode, the green snail icon will flash.



Figure 23. Function Speed Icons



Figure 24. Function Speed Icons

5.6 CAN BUS LOST

When the control system senses a communication loss with any of the control modules (BLAM, Chassis, UGM, or Jib Control Module), the display will show a CAN Bus Communication lost until the communications are reset.

Note: There is no way to get the active DTCs so, the previously active DTCs will be scrolling along with the CAN Bus Communication lost DTC. This DTC needs to be cleared in order for the communications to reset.

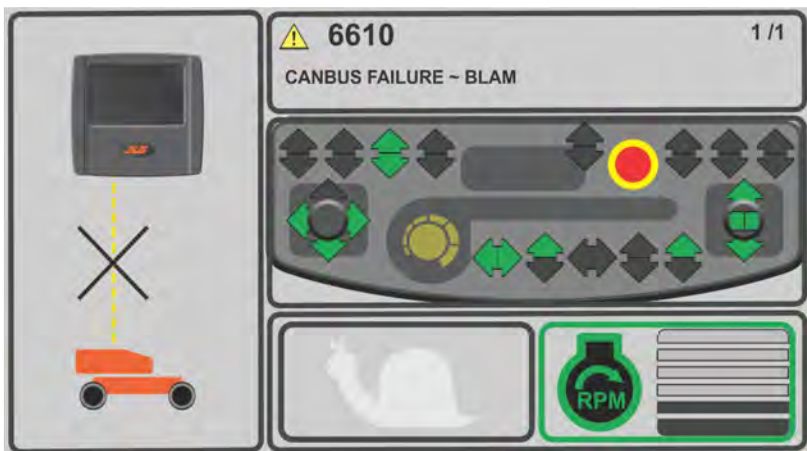

Figure 25. CAN Bus Lost Screen

5.7 TAKE FOOT OUT

When the footswitch is pressed and the control system senses a Take Foot Out DTC, the display shows the Take Foot Out image in the machine status tray.

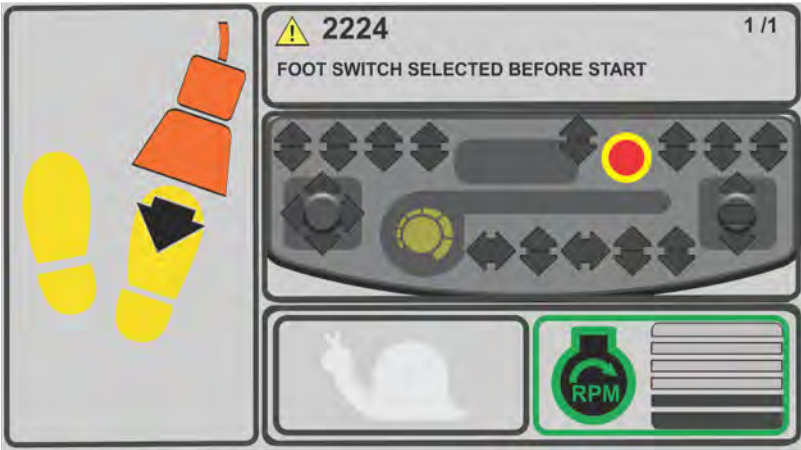

Figure 26. Take Foot Out Screen

5.8 PUT FOOT IN

When the operator operates the machine without putting his foot on switch, Put Foot In DTC becomes active after timeout.

When put foot in DTC is active, the display shows Put Foot In image in the machine status tray.

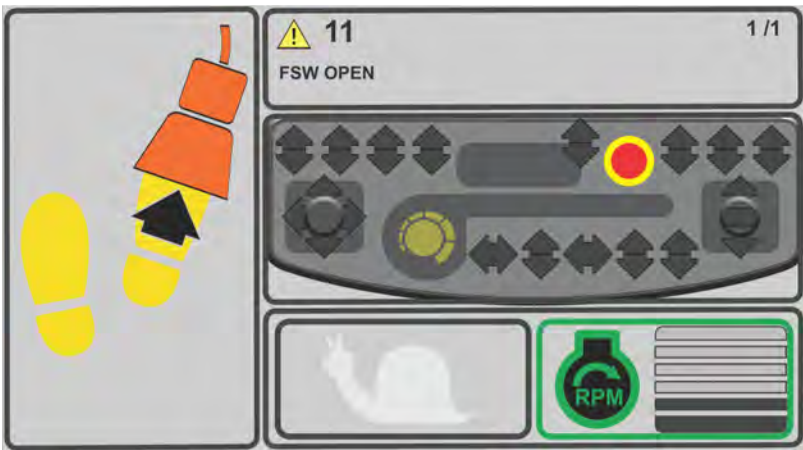

Figure 27. Put Foot In Screen

5.9 BOOM CONTROL SYSTEM (BCS) LAMP ON

When the boom control system senses the platform is outside the operating area, the BCS Lamp will be ON. When the BCS Lamp is ON, the display shows a red octagon in the machine status tray indicating a potentially hazardous situation.

- The DTCs that triggered this BCS Lamp will be scrolled in the DTC tray.

Note: The available controls will be different among the different DTCs. The image below is ONLY for envelope violation.

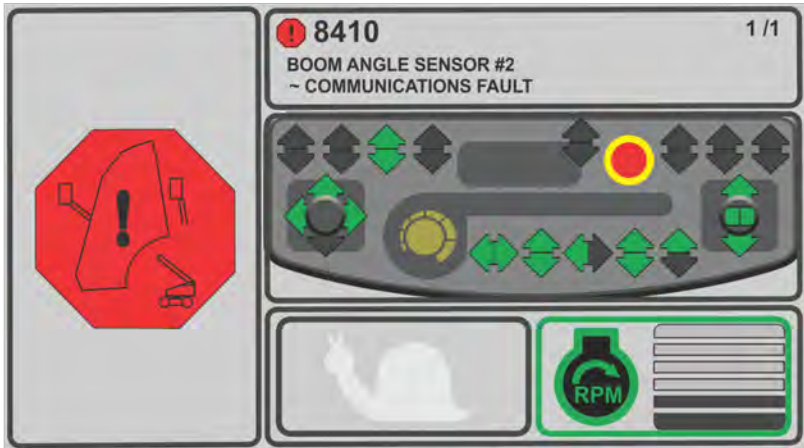

Figure 28. BCS Lamp Screen

5.10 WIRE ROPE SERVICE

When the control system senses a loose or broken wire rope, the Wire Rope Service lamp on the platform panel is lit. When the lamp is lit, the display shows a red octagon wire rope service indicator in the machine status tray.

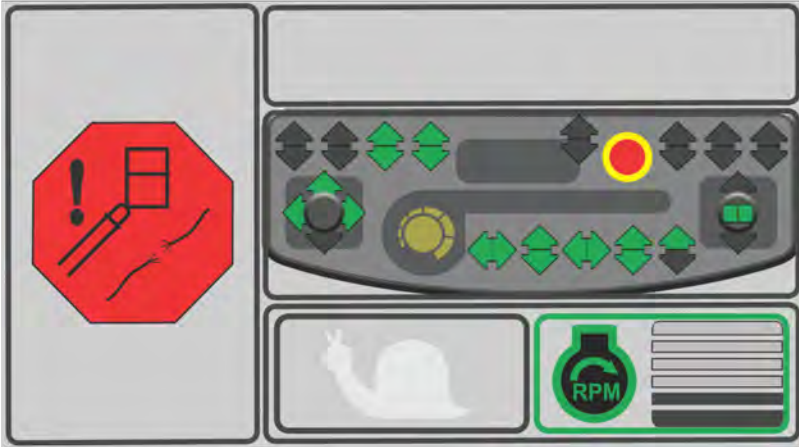

Figure 29. Wire Rope Service Screen

5.11 PLATFORM LEVEL

Whenever the control system senses a DTC with the platform level, the platform level lamp is lit on the platform console. When this lamp is lit, the display shows a red octagon platform level DTC indicator in the machine status tray.

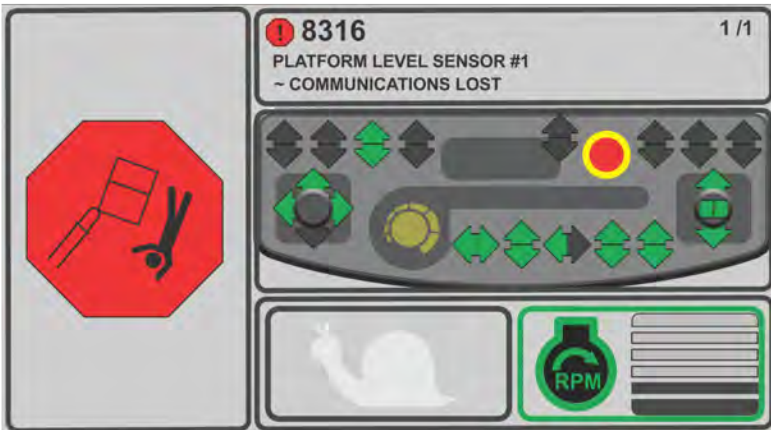

Figure 30. Level System DTC Screen

5.12 PLATFORM OVERLOAD

When the boom control system senses that the platform is overloaded, the Platform Overload indicator on the platform console will be lit.

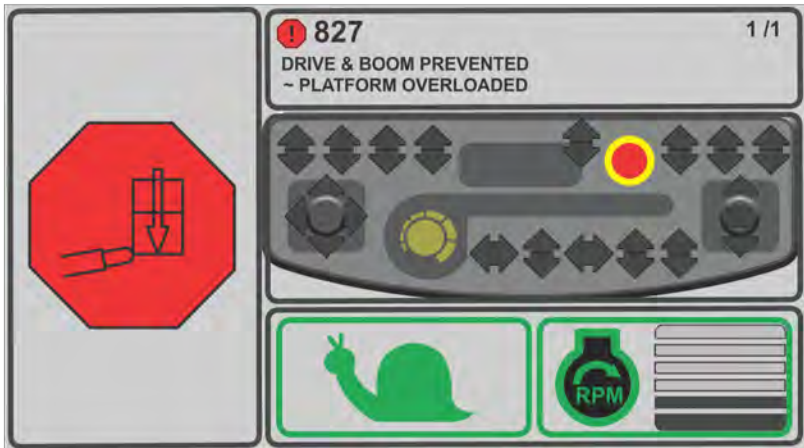

Figure 31. Overload DTC Screen

5.13 CAPACITY MODE ERROR

If the operator selects the incorrect capacity mode for the jib configuration (i.e., if the operator is in Unrestricted mode with the jib completely telescoped out, and changes the capacity to Restricted mode), the capacity mode indicator icon will flash in the Machine Status tray every second.

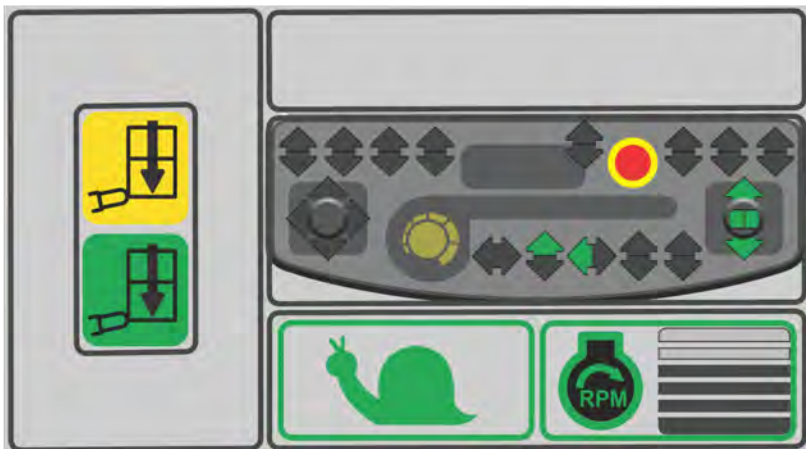

Figure 32. Capacity Mode Error Screen

5.14 CHASSIS STATUS

5.14.1 Axles Retracted In Transport Position

When the axles are retracted regardless of engine state, the display shows the following screen. The Axles Retracted image is shown on the left side of the display or machine status tray. This image will be shown until the axles are extended.

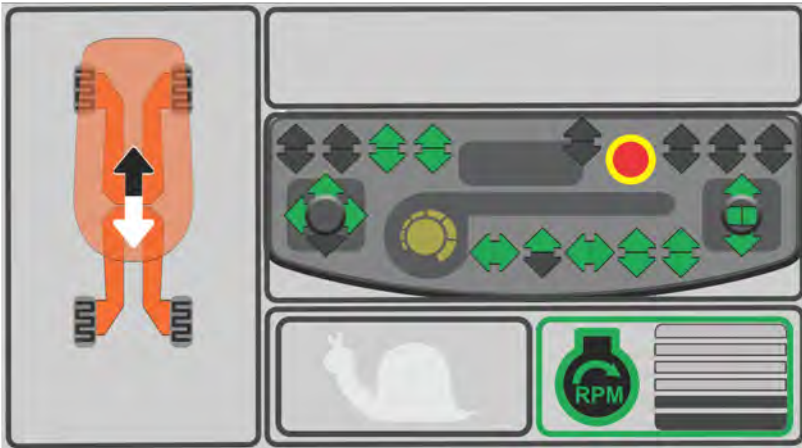

Figure 33. Axles Retracted Screen

5.14.2 Axles Extended

When the axles are extended for the first time (meaning previous state is retracted and current state is extended), regardless of the Engine state, the Axles Extended image will show up on the machine status tray for first 3 seconds.

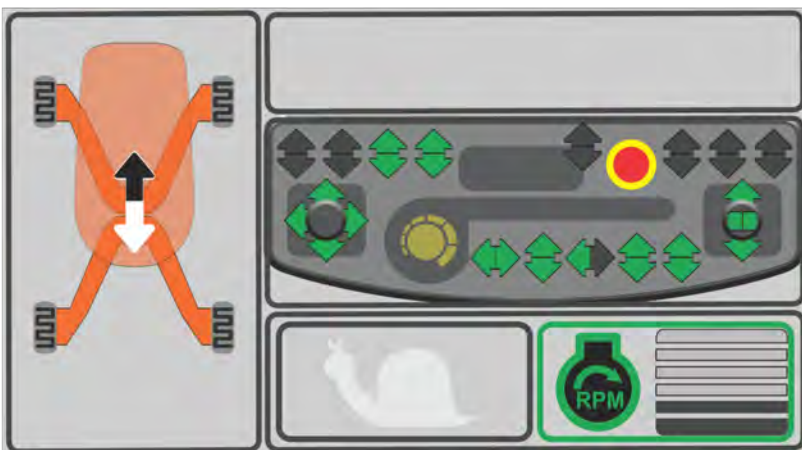

Figure 34. Axles Extended Screen

5.14.3 Axles Retracted In Out of Transport Position

When the axles are retracted and the machine is in out of transport position, the display will switch between axles extended and retracted every 0.5 seconds to tell the operator to extend the axles so the boom can be raised.

5.14.4 Axles In Transient State

When the operator is extending or retracting the axles, the Axles In Transient State screen will show and the arrows showing axle travel direction will flash. When the axles are not fully extended or retracted and no axle functions are selected, the green arrows will show steadily.

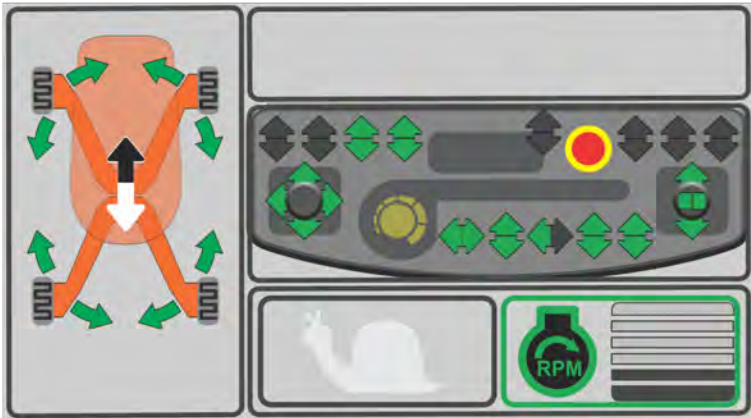

Figure 35. Axles In Transient State Screen

5.15 MACHINE TILTED MODE

When the control system senses the chassis is on an excessive slope, the display will show the Machine Tilted image in the machine status tray.

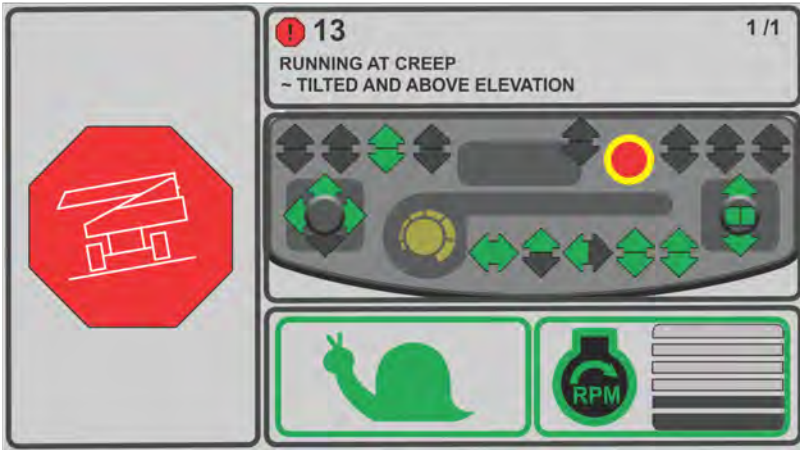

Figure 36. Machine Tilted Mode Screen

5.16 ENVELOPE STATUS

Mode	Boom	Platform	Envelope Color
Unrestricted	Orange	Black	Yellow
Restricted	Orange	Black	Green

Example 1: Platform is not at the edge of the envelope

- When Unrestricted or Restricted mode is selected, the display shows envelope image in the machine status tray.
- The color code for the envelope matches the capacity select decals on the machine.
- When the control system senses that the axles are fully extended, the selected envelope shows up on the machine status tray.
- The display shows animated boom length and boom angle information along with the envelope.
- Boom movement is proportional to the envelope boundaries.
- Platform location is always shown at the end of the boom.

- When operator switches from Unrestricted to Restricted mode, the envelope shrinks to indicate reduced operating envelope.

Example 2: Platform is edge of the envelope

- When Unrestricted or Restricted mode is selected, the display flashes snail image at a rate of 0.5 seconds in the machine status tray.
- The envelope color will match the weight mode selected.

Example 3: Unrestricted mode with envelope tilt condition

- When on the Unrestricted envelope screen, if the operator experiences a tilt condition where tilt is less than what the machine is configured for, then the envelope will shrink further to show that the new envelope.
- Display shows animated boom length and boom angle information along with the new envelope.
- Boom movement is proportional to envelope boundaries.
- Platform location is always at the end of the boom.

Example 4: Restricted mode with envelope tilt condition

- When on the Restricted envelope screen, if the operator experiences a tilt condition where tilt is less than what the machine is configured for, then the envelope will shrink further to show that the new envelope.
- Display shows animated boom length and boom angle information along with the new envelope.
- Boom movement is proportional to envelope boundaries.
- Platform location is always at the end of the boom.

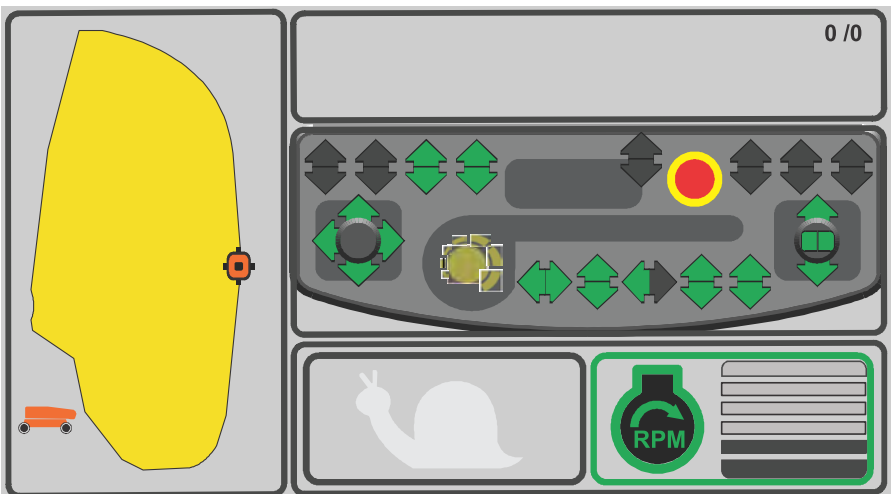

Figure 37. Unrestricted Mode Screen

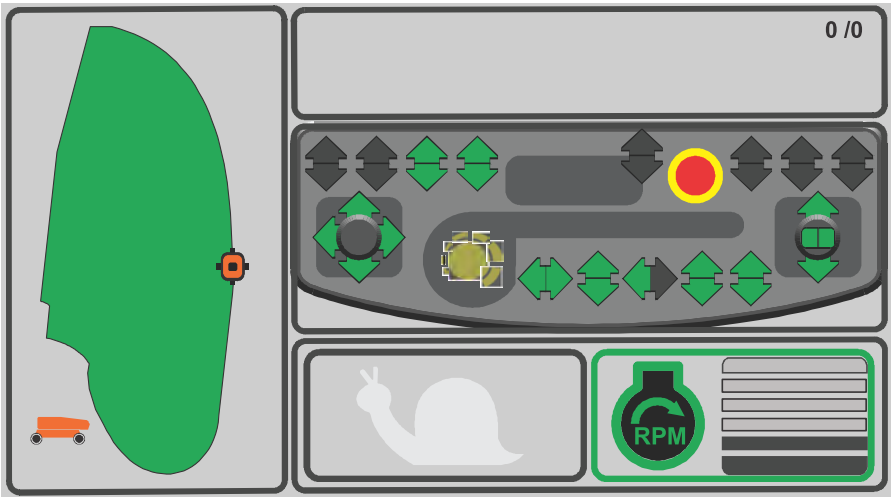

Figure 38. Restricted Mode Screen

5.17 MACHINE MODEL UNKNOWN

As soon as the machine is powered up, the control system checks the model of the machine and if the model is neither 1500AJP, 1500SJ, nor 1850SJ the display will show the Machine Model Unknown image on the machine status tray.

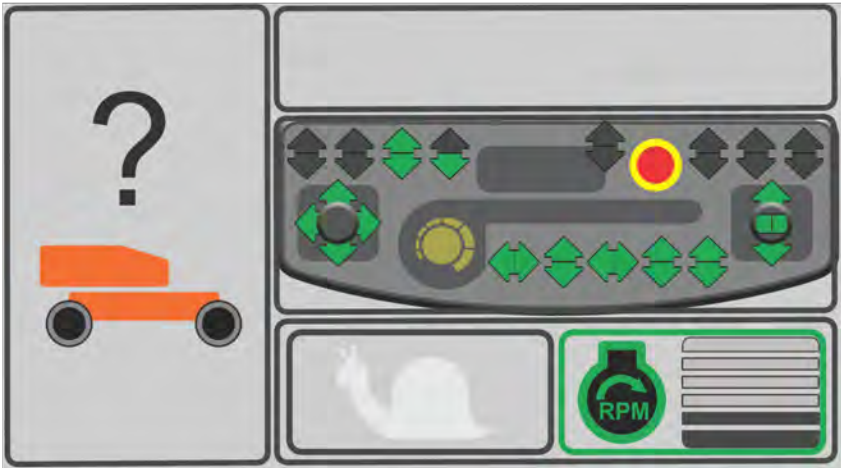

Figure 39. Machine Model Unknown Screen

5.18 SELECTIVE CATALYTIC REDUCTION (SCR) CLEANING

SCR icons will display in the icons tray when there is a cleaning event or warning active. The SCR Warning Icon will display when cleaning is required. Refer to [Section — Machine Operation](#) for more information. The SCR Cleaning Icon will display when:

- JLG Control System requests cleaning
- Crystallization is detected
- The machine is in cleaning mode
- Cleaning process has failed

The High Exhaust System Temperature (HEST) will show in the icons tray when exhaust temperature reaches 1022° F (550° C) degrees. The Diesel Exhaust Fluid (DEF) icon displays the level of fluid in the DEF tank in 1% increments.

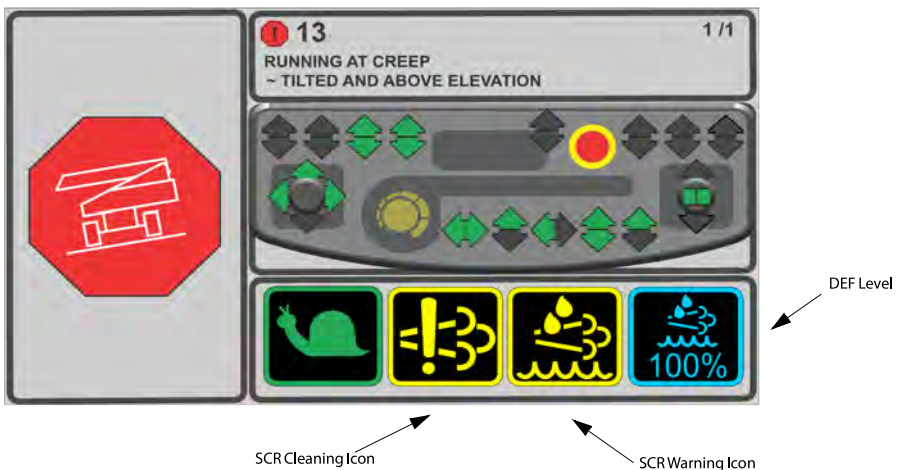

Figure 40. SCR Cleaning Screen - Sheet 1 of 2

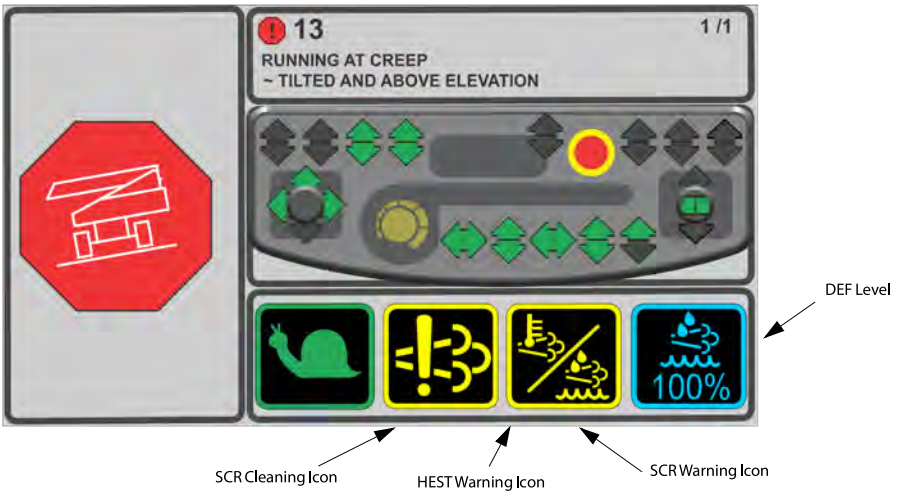

Figure 41. SCR Cleaning Screen - Sheet 2 of 2

SECTION 6

Emergency Procedures

6.1 GENERAL

This section explains the steps to be taken in case of an emergency situation during operation.

6.2 INCIDENT NOTIFICATION

JLG Industries, Inc. must be notified immediately of any incident involving a JLG product. Even if no injury or property damage is evident, the factory should be contacted by telephone and provided with all necessary details.

- USA: 877-JLG-SAFE (554-7233)
- EUROPE: (32) 0 89 84 82 20
- AUSTRALIA: (61) 2 65 811111
- E-mail: ProductSafety@JLG.com

Failure to notify the manufacturer of an incident involving a JLG Industries product within 48 hours of such an occurrence may void any warranty consideration on that particular machine.

NOTICE

Following any incident, thoroughly inspect the machine and test all functions first from the ground controls, then from the platform controls. Do not lift above 3 m (10 ft.) until you are sure that all damage has been repaired, if required, and that all controls are operating correctly.

6.3 EMERGENCY OPERATION

6.3.1 Operator Unable to Control Machine

If the platform operator is pinned, trapped or unable to operate or control machine, do the following:

1. Other personnel should operate the machine from ground controls only as required.
2. Other qualified personnel on the platform may use the platform controls.

WARNING

Do not continue operation if controls do not function properly.

3. Cranes, forklift trucks or other equipment can be used to remove platform occupants and stabilize motion of the machine.

6.3.2 Platform or Boom Caught Overhead or Boom Movement Prevented by Boom Control System

Lowering the boom onto an object or structure may cause the boom control system to prevent movement of the machine. This can include movement necessary to lift the boom off the object. Additionally, if the platform or boom becomes jammed or snagged in overhead structures, movement of the boom can be regained by doing the following:

1. Shut off the machine.
2. Rescue all people in the platform before freeing the machine. Personnel must be out of the platform before operating any controls on the machine.
3. Use cranes, forklifts, or other equipment to stabilize motion of the machine to prevent a tip over as required.
4. From the ground controls, use the Auxiliary Power System to carefully free the platform or boom from the object.
5. Once clear, restart the machine and return the platform to a safe position.
6. Inspect the machine for damage. If the machine is damaged or does not operate properly, turn off the machine immediately. Report the problem to the proper maintenance personnel. Do not operate the machine until it is declared safe for operation.

6.4 EMERGENCY TOWING PROCEDURES

Towing this machine is prohibited, unless properly equipped. However, provisions for moving the machine have been incorporated. For specific procedures, refer to the Machine Operation section.

6.5 MACHINE SAFETY SYSTEM OVERRIDE (MSSO) (IF EQUIPPED)

The Machine Safety System Override (MSSO) is only to be used to retrieve an operator that is pinned, trapped, or unable to operate the machine. The MSSO will override function controls that are locked out from the platform and ground consoles. An example of this would be in the case of Load Sense System activation.



Note: If the MSSO functionality is used, a fault indicator is set with a fault code in the JLG Control System which must be reset by a qualified JLG Service Technician.

Note: No functional checks of the MSSO system are necessary. The JLG Control System will set a Diagnostic Trouble Code if the control switch is faulty.

Note: If the engine is not running, MSSO will function through the Auxiliary Power system.

To operate the MSSO, perform the following:

1. From the Ground Control Console, place the Platform/Ground Select switch into the Ground position.
2. Pull out the Power/Emergency Stop control switch.
3. Start the engine.
4. Press and hold the MSSO switch and the control switch for the desired function.

This Page is intentionally left blank

SECTION 7

Accessories

7.1 AVAILABLE ACCESSORIES AND RELATIONSHIP TABLE

Table 5. Available Accessories Table

Accessory	Market						
	ANSI (USA Only)	ANSI	AUS	CE/UKCA	CSA	GB (China)	MOL 70 (Japan)
Bolt-On External Fall Arrest	√	√	√		√	√	√
Cable Ladder Carrier			√				
Fabric Mesh to Mid Rail (30" x 48") (36" x 72") (36" x 96")	√	√	√			√	
Fabric Mesh to Top Rail (36" x 72")	√	√			√	√	
Fabric Mesh to Top Rail (36" x 96")	√				√		
Fall Arrest Platform (36" x 96")	√		√				
Nite Bright®	√	√	√	√	√	√	√
Pipe Racks	√		√	√	√		
Platform Mesh to Mid Rail (30" x 48") (36" x 72") (36" x 96")	√	√	√			√	
Platform Mesh to Top Rail (36" x 72")	√	√			√	√	
Platform Mesh to Top Rail (36" x 96")	√				√		

Table 5. Available Accessories Table (continued)

Accessory	Market						
	ANSI (USA Only)	ANSI	AUS	CE/UKCA	CSA	GB (China)	MOL 70 (Japan)
Platform Top Rail Extension	√	√	√	√	√	√	√
Platform Work Lights	√	√	√	√	√	√	√
Platform Work Surface	√	√	√	√	√	√	√
SkyCutter®	√	√			√		√
SkyGlazier®	√		√		√		
SkyPower® 7.5 kW	√	√	√		√		√
Generator 4 kW	√	√	√	√	√		√
SkySense®	√	√	√	√	√	√	√
SkySense® Platform Bumper Padding	√	√	√	√	√	√	√
SkyWelder®	√	√	√		√		√
Soft Touch	√	√	√	√	√	√	√
Storage Tray	√	√	√	√	√	√	√

Table 6. Accessories/Options Relationship Table

Accessory	Required Item	Compatible With (Note 1)	Incompatible With	Interchangeable With (Note 2)
Cable Ladder Carrier			Bolt-On Fall Arrest, Fall Arrest Platform, Platform MTR**, Platform Top Rail Extension, SkyGlazier, SkySense, SkySense Platform Bumper Padding	
Nite Bright			Fall Arrest Platform, Platform MMR*, Platform MTR**, Platform Work Lights, SkySense Platform Bumper Padding, Storage Tray, Top Rail Extension	
Pipe Racks		SkyPower	Platform MMR*, Platform MTR**, SkySense, Soft Touch	
Platform Work Surface			Platform MMR*, Platform MTR**, SkySense, SkySense Platform Bumper Padding, Soft Touch, 30" x 36" Platform, 30" x 48" Platform	
SkyAir		SkyCutter, SkyGlazier, SkyWelder		
SkyCutter		SkyPower	30" x 36" Platform, Pipe Racks, Platform/Fabric MMR*, Platform/Fabric MTR**, SkySense, SkySense Platform Bumper Padding, Soft Touch, Storage Tray	SkyGlazier
SkyGlazier		SkyPower	4 ft Platform, Bolt-On Fall Arrest, Cable Ladder Carrier, Fall Arrest Platform, Pipe Racks, Platform/Fabric MMR*, Platform/Fabric MTR**, SkySense, SkySense Platform Bumper Padding, Soft Touch, Top Rail Extension, Tri-Entry Platform, 30" x 36" Platform	SkyCutter, SkyWelder
SkyPower		Nite Bright, SkyCutter, SkyGlazier, SkyWelder		
SkySense		SkyPower	Bolt-On Fall Arrest, Cable Ladder Carrier, Pipe Racks, Fabric MMR*, Fabric MTR**, SkyGlazier, SkyWelder, Soft Touch, Top Rail Extension	
SkySense Platform Bumper Padding		SkySense	Cable Ladder Carrier, Nite Bright, SkyWelder, Platform/Fabric MTR, Platform/Fabric MMR, Soft Touch, Storage Tray, Top Rail Extension, Sky Glazier, Sky Cutter, Platform Work Surface	

Table 6. Accessories/Options Relationship Table (continued)

Accessory	Required Item	Compatible With (Note 1)	Incompatible With	Interchangeable With (Note 2)
SkyWelder	SkyPower	Nite Bright, SkyCutter	30" x 36" Platform, Pipe Racks, Platform/Fabric MMR*, Platform/Fabric MTR**, SkySense, SkySense Platform Bumper Padding, Soft Touch, Storage Tray	SkyGlazier
Soft Touch		SkyPower	Bolt-On Fall Arrest, Nite Bright, Pipe Racks, Platform/Fabric MTR**, Platform Work Lights, Platform Work Surface, SkyCutter, SkyGlazier, SkySense, Sky-Welder, Storage Tray, Top Rail Extension, Tri-Entry Platform	
Storage Tray			Bolt-On Fall Arrest, Platform MMR*, Platform MTR**, SkyCutter, SkyWelder, SkySense Platform Bumper Padding, Soft Touch, Top Rail Extension	
Note: 1. Any non - "Sky" accessory not listed under "Incompatible With" is assumed to be compatible.				
Note: 2. Can be used on the same unit but not simultaneously.				
* MMR = Mesh to Mid Rail; ** MTR = Mesh to Top Rail				

7.2 BOLT-ON EXTERNAL FALL ARREST

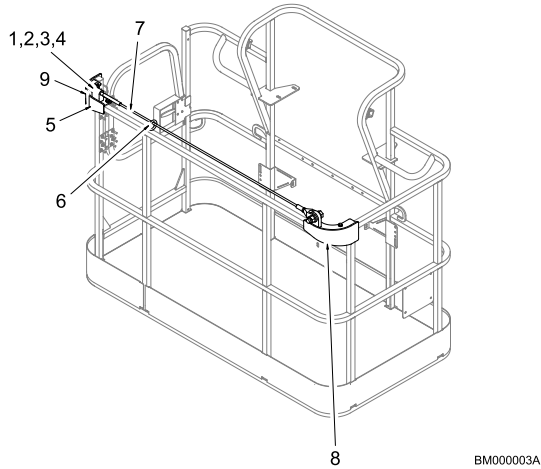

Figure 42. Bolt-On External Fall Arrest System

- | | | |
|----------------------|--------------------|---------------|
| 1. Belleville Washer | 4. Jam Nut | 7. Cable |
| 2. Washer | 5. LH Bracket | 8. RH Bracket |
| 3. Hex Nut | 6. Attachment Ring | 9. Decal |

The bolt-on external fall arrest system is designed to provide a lanyard attach point while allowing the operator to access areas outside the platform. Exit/Enter the platform through the gate area only. The system is designed for use by one person.

Personnel must use fall protection at all times. A full body harness is required with lanyard not to exceed 6 ft (1.8 m) in length, that limits the maximum arrest force to 900 lb (408 kg).

External Fall Arrest System capacity is 310 lb (140 kg) - one (1) person maximum.

Do not move platform during use of the external fall arrest system.

⚠ WARNING

Do not operate any machine functions while outside of platform. Be careful when entering/exiting the platform at elevation.

⚠ WARNING

If the external fall arrest system is used to arrest a fall or is otherwise damaged, the entire system must be replaced and the platform fully inspected before returning to service. Refer to the service manual for removal and installation procedures.

NOTICE

The external fall arrest system requires an annual inspection and certification. The annual inspection and certification must be performed by a qualified person other than the user.

7.2.1 Inspection Before Use

The external fall arrest system must be inspected before each use of the machine. Replace components if there are any signs of wear or damage.

Before each use, perform a visual inspection of the following components:

- Cable: Inspect cable for proper tension, broken strands, kinks, or any signs of corrosion.

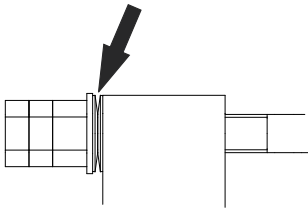

Figure 43. Incorrect Gap

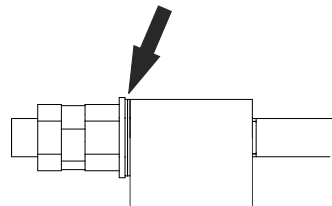

Figure 44. Correct Gap

Note: There should be no visible gap between the two Belleville washers when setting proper cable tension. If any gap is shown between the two Belleville washers, the cable tension is incorrect.

- Fittings & Brackets: Ensure all fittings are tight and there are no signs of fractures. Inspect brackets for any damage.

- Attachment Ring: No cracks or signs of wear are acceptable. Any signs of corrosion requires replacement.
- Attaching Hardware: Inspect all attaching hardware to ensure there are no missing components and hardware is properly tightened.
- Platform Rails: No visible damage is acceptable.

7.3 CABLE LADDER CARRIER

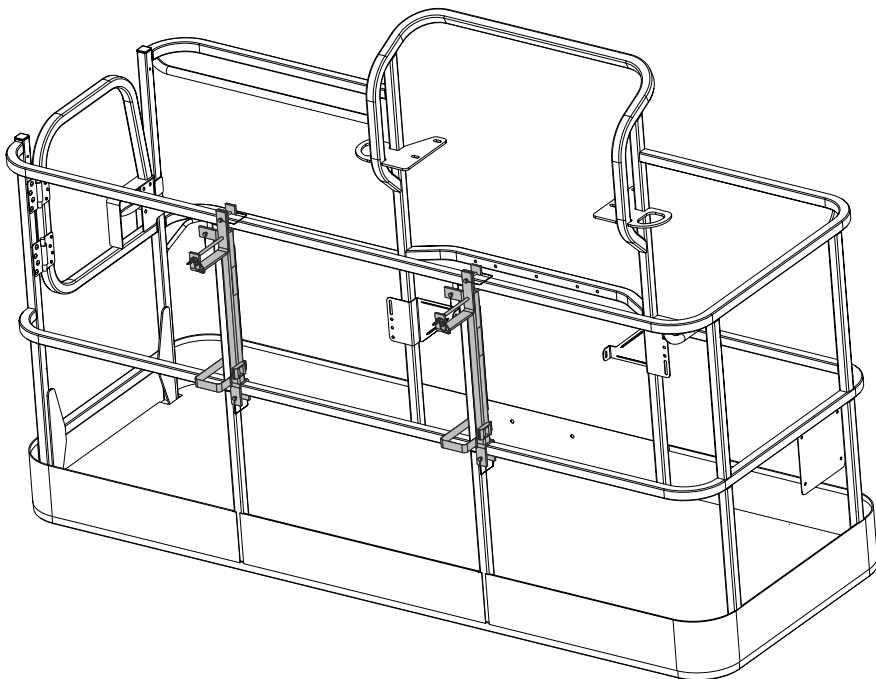

BM000362

Figure 45. Cable Ladder Carrier

The Cable Ladder Carrier accessory consists of two vertical brackets mounted to the outside of the platform used to carry a "ladder" style cable tray.

7.4 FABRIC MESH TO MID OR TOP RAIL

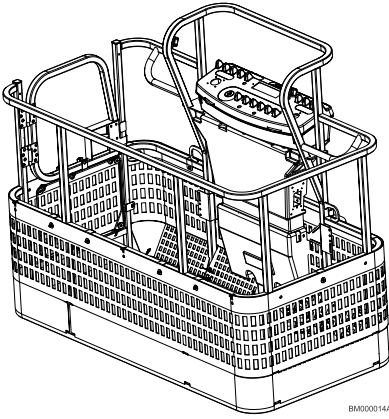

Figure 46. Fabric Mesh to Mid Rail

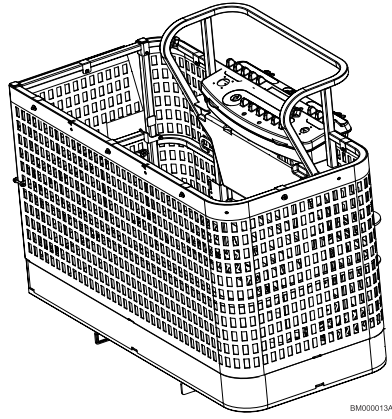

Figure 47. Fabric Mesh to Top Rail

The Fabric Mesh accessory consists of a flame retardant, lightweight mesh which is attached to the mid platform rail **or** the top platform rail.

7.5 FALL ARREST PLATFORM

Note: See the JLG External Fall Arrest System manual (PN 3128935) for more detailed information.

The external fall arrest system is designed to provide a lanyard attach point while allowing the operator to access areas outside the platform. Exit/enter the platform through the gate area only. The system is designed for use by one person.

Personnel must use fall protection at all times. A full body harness is required with lanyard not to exceed 6 ft (1.8 m) in length, that limits the maximum arrest force to 900 lb (408 kg) for the transfaster type and 1350 lb (612 kg) for the shuttle type fall arrest system.

7.5.1 Safety Precautions

⚠ WARNING

Do not operate any machine functions while outside the platform. Use caution when entering/exiting the platform at elevation.

7.6 NITE BRIGHT®

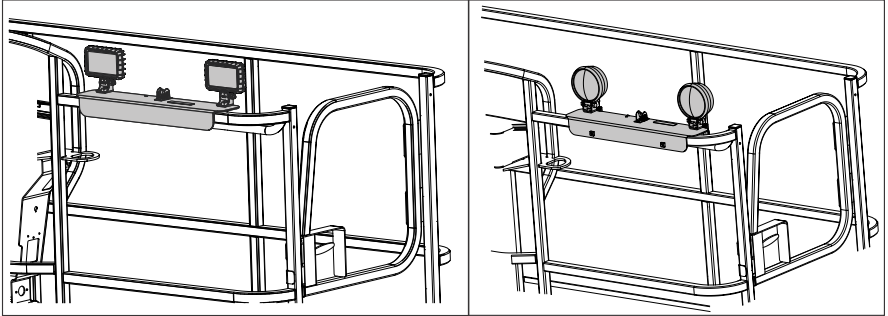

Figure 48. Nite Bright

The Nite Bright light package* consists of two 40W lights mounted to the platform railing.

* Appearance of Nite Bright lights may vary.

7.7 PIPE RACKS

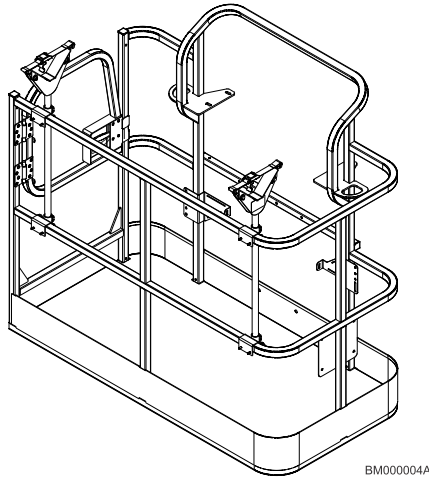

Figure 49. Pipe Racks

Pipe Racks provide a way to store pipe or conduit inside the platform in order to prevent rail damage and optimize platform utility. This accessory consists of two racks with adjustable straps to secure the load in place.

7.7.1 Capacity Specifications (Australia Only)

Max. Capacity in Racks	Max. Platform Capacity (With Max. Weight in Racks)
80 kg	184 kg

Max. Length of Material in Racks: 6.0 m

Min. Length of Material in Racks: 2.4 m

7.7.2 Safety Precautions

WARNING

Reduce platform capacity by 100 lb (45.5 kg) when installed.

WARNING

Weight in racks plus weight in platform must not exceed rated capacity.

NOTICE

The maximum load in the racks is 180 lb (80 kg) evenly distributed between the two racks.

NOTICE

The maximum length of material in racks is 20 ft (6.1 m).

- Ensure no personnel are beneath the platform.
- Do not exit platform over rails or stand on rails.
- Do not drive machine without material secured.
- Return racks to the stowed position when not in use.
- Use this option only on approved models.

7.7.3 Preparation and Inspection

- Ensure racks are secured to the platform rails.
- Replace torn or frayed tie-down straps.

7.7.4 Operation

1. To prepare racks for loading, remove locking pins, rotate each rack 90 degrees from stowed to working position, then secure with locking pins.
2. Loosen and remove tie-down straps. Place material on racks with weight evenly distributed between both racks.
3. Route the tie-down straps at each end across loaded material and tighten.

4. To remove material, loosen and remove tie-down straps, then carefully remove material from racks.

Note: Reinstall tie-down straps across any remaining material before continuing machine operations.

7.8 PLATFORM MESH TO MID OR TOP RAIL

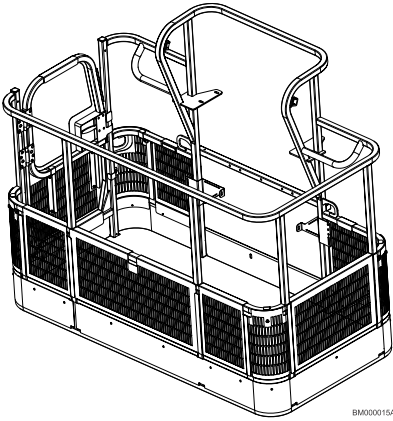

Figure 50. Platform Mesh to Mid Rail

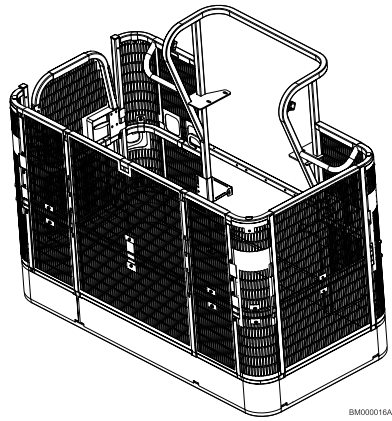
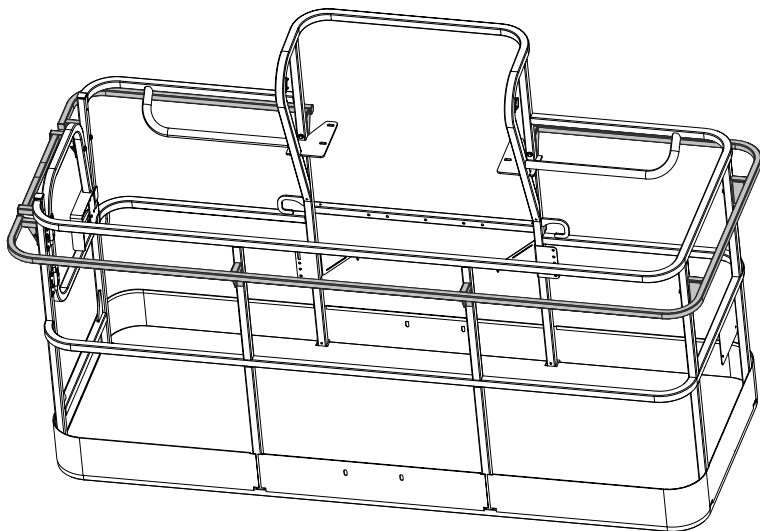

Figure 51. Platform Mesh to Top Rail

The Platform Mesh to Mid Rail accessory consists of stainless steel mesh attached to the platform mid rail.

The Platform Mesh to Top Rail accessory consists of lightweight, aluminum mesh attached to the platform top rail.

7.9 PLATFORM TOP RAIL EXTENSION



BM000017A

Figure 52. Platform Top Rail Extension

The Platform Top Rail Extension accessory consists of an additional bar extending from all sides of the platform.

7.10 PLATFORM WORK LIGHTS

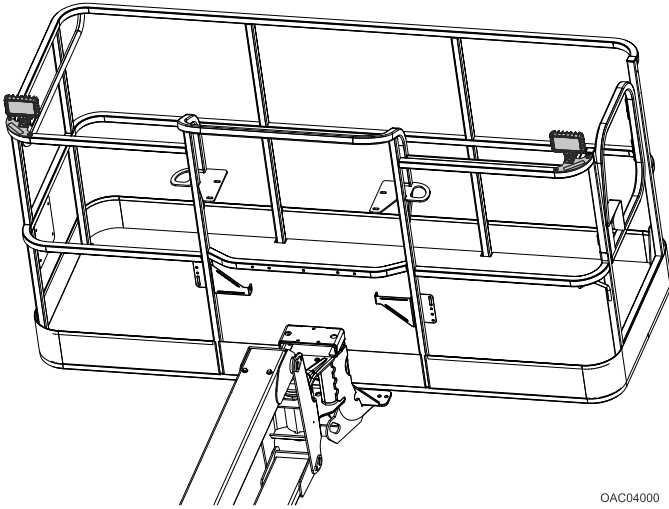

OAC04000

Figure 53. Platform Work Lights

The Platform Work Lights accessory consists of two 12V lights mounted to the platform railing.

7.11 PLATFORM WORK SURFACE

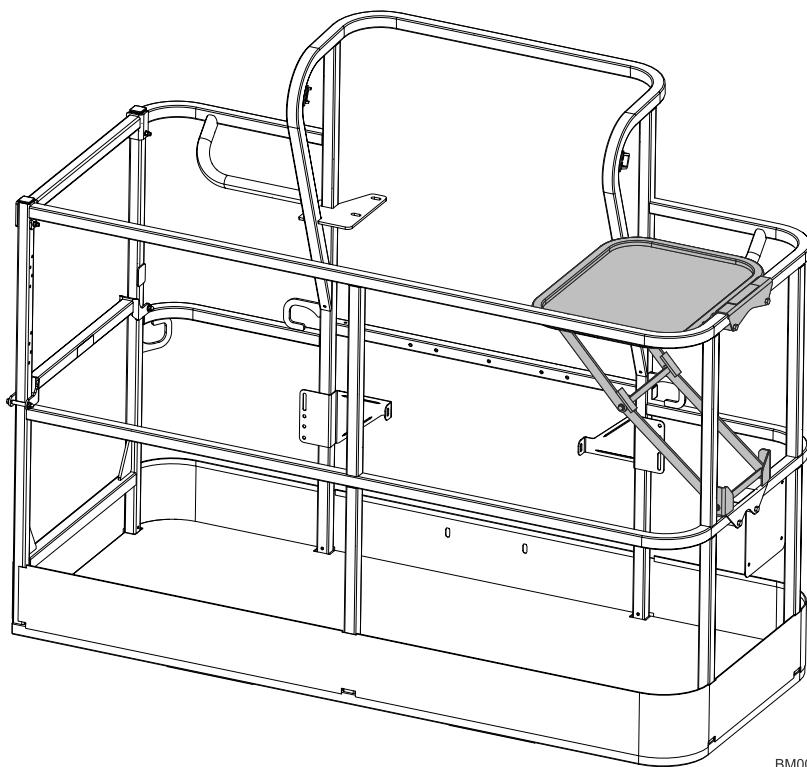

BM00027f

Figure 54. Platform Work Surface

The platform work surface option consists of a corner tray bolted onto the top and mid rails of the platform.

7.12 SKYCUTTER®

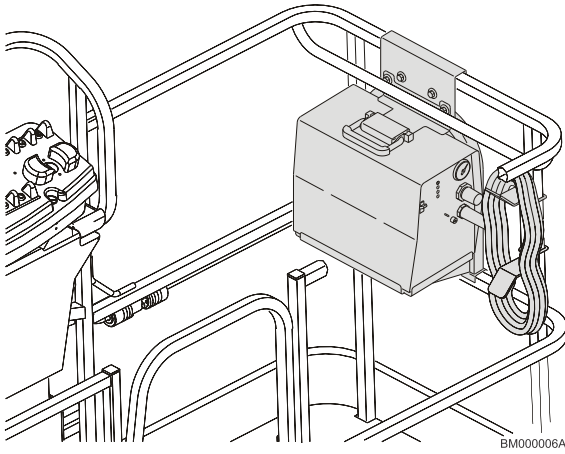

Figure 55. SkyCutter System

SkyCutter is capable of cutting up to a thickness of 3/8" metal. It can produce 27 A at 92 VDC at 35% duty cycle or 14 A at 92 VDC at 60% duty cycle. It receives power from the SkyPower system.

7.12.1 Safety Precautions

⚠ WARNING

Do not overload platform.

⚠ WARNING

De-rate the platform by 70 lb (32 kg) when accessory is in the platform.

- Check for cracked welds and damage to plasma supports.
- Check for secure installation of cutter and bracket.
- Ensure no personnel are beneath platform.
- Do not exit platform over rails or stand on rails.
- Use this option only on approved models.
- Keep lanyard attached at all times.
- Use correct cutting settings.
- Do not use electrical cords without ground.

- Do not use electrical tools in water.
- Do not cut platform.
- Do not ground through the platform.
- Wear proper cutting apparel.
- Do not drive machine while connected to external air/gas sources.

7.12.2 Generator Output

Engine Speed of 1800 rpm +/- 10%.

ANSI Specifications:

- 3-phase: 240 V, 60 Hz, 7.5 kW
- 1-phase: 240 V/120 V, 60 Hz, 6 kW

7.12.3 Preparation and Inspection

- Connect ground clamp to metal being cut.
- Ensure there is a good ground connection.

7.12.4 Operation

Start the engine, turn on the generator, then turn on the plasma cutter.

See the Miller Plasma Cutter Owner's Manual (PN 3128420) for more information.

7.12.5 Accessory Ratings

Spec.	Rated Output	Amperes Input@ Rated Output, 60 Hz, 1-Phase	kVa/kW	Plasma Gas	Plasma Gas Flow/ Pressure	Rated Cutting Capacity @ 10 IPM	Max. OCV
120 Volts ±10% (20 A)	27 A @ 91 VDC@ 20%	28.8 max;	3.4 kVa	Air or Nitrogen Only @ 90 - 120 psi (621 - 827 kPa)	4.5 cfm (129 L/Min) @ 60 psi (414 kPa)	3/8 in (10 mm)	400 VDC
	Duty Cycle	0.30 *	3.2 kW				
120 Volts ±10% (15 A)	20 A @ 88 VDC@ 35%	20.6 max;	2.5 kVa				
	Duty Cycle	0.30 *	2.3 kW				
240 Volts ±10% (27 A)	27 A @ 91 VDC@ 35%	13.9 max;	3.3 kVa				
	Duty Cycle	0.13 *	3.0 kW				

* While idling.

7.13 SKYGLAZIER®

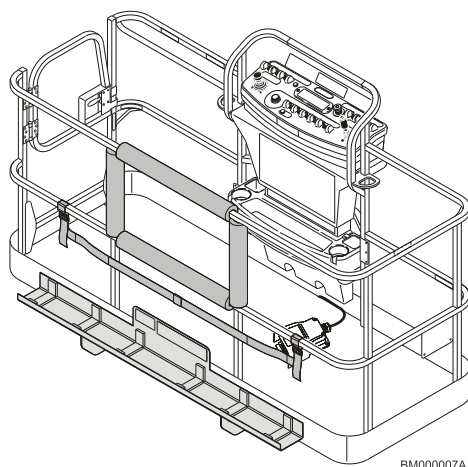

Figure 56. SkyGlazier System

SkyGlazier allows glaziers to position panels efficiently. The glazier package consists of a tray that attaches to the bottom of the platform. The panel rests on the tray and against top-rail of the platform, which is padded to prevent damage. SkyGlazier includes a strap to secure the panel to the platform rail.

7.13.1 Capacity Specifications

Capacity Zone *	Max. Tray Capacity	Max. Platform Capacity With Max. Weight in Tray
500 lb (227 kg/230 kg)	150 lb (68 kg)	250 lb (113 kg)
550 lb (249 kg/250 kg)	150 lb (68 kg)	250 lb (113 kg)
600 lb (270 kg/272 kg)	150 lb (68 kg)	250 lb (113 kg)
660 lb (299 kg/300 kg)	150 lb (68 kg)	350 lb (160 kg)
750 lb (340 kg)	150 lb (68 kg)	440 lb (200 kg)
1000 lb (450 kg/454 kg)	250 lb (113 kg)	500 lb (227 kg)
* Refer to the capacity decals installed on the machine for capacity zone information.		
Required Platform Type: Side-Entry		

Capacity Zone *	Max. Tray Capacity	Max. Platform Capacity With Max. Weight in Tray
Maximum Dimensions of Panel: 32 sq ft (3 sq m)		
Maximum Wind Speed: 20 mph (32 kph)		

7.13.2 Safety Precautions

WARNING

Ensure panel is secured with strap.

WARNING

Do not overload tray or platform. Total machine capacity is reduced when tray is installed.

WARNING

With SkyGlazier installed, the original platform capacity ratings are reduced as specified in the specifications table above. Do not exceed the new platform capacity rating. Refer to capacity decal located on tray.

WARNING

An increase of the area exposed to the wind will decrease stability. Limit panel area to 32 sq ft (3 sq m). Maximum allowable wind speed is 20 mph (32 kph).

- Ensure no personnel are beneath platform.
- Do not exit platform over rails or stand on rails.
- Remove tray when not in use.
- Use this option only on approved models.

7.13.3 Preparation and Inspection

- Check for cracked welds and damage to tray.
- Ensure tray is properly secured to platform.
- Ensure strap is not torn or frayed.

7.13.4 Operation

1. Load SkyGlazier tray with panel.

2. Position panel to its desired location on the tray.
3. Route the adjustable strap around the panel and tighten until secure.

7.14 SKYPOWER® 7.5 KW AND GENERATOR 4 KW

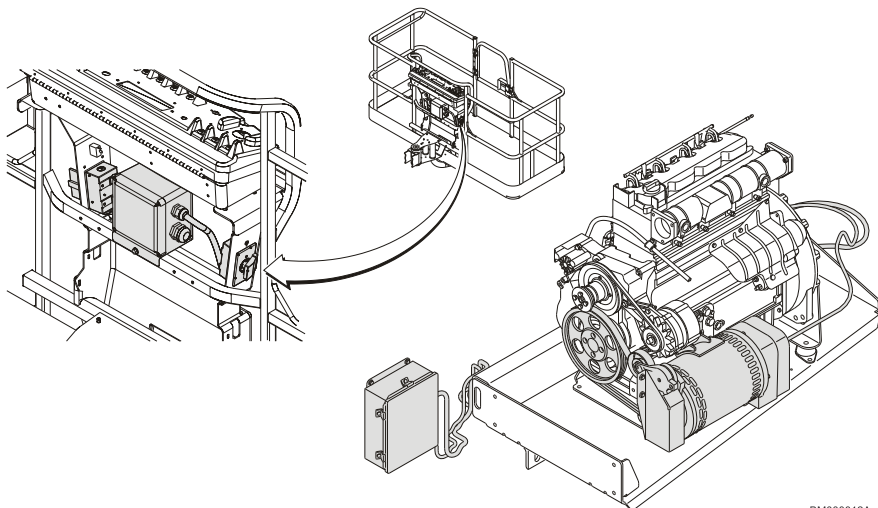

BM000012A

Figure 57. SkyPower and Generator Systems

The SkyPower and generator systems supply AC power to the platform through an AC receptacle to run tools, lights, cutting, and welding equipment.

All power regulation components are located in a watertight box connected by cable to the generator. The generator supplies power when running at the specified speed with the power switch on (switch is located on platform). A two-pole, 20 A (4 kW) or a three-pole, 30 A (7.5 kW) circuit breaker protects the generator from overload.

7.14.1 Output

SkyPower 7.5 kW Specifications:

- 3-phase: 240 V, 60 Hz, 7.5 kW (Peak: 8.5 kW)
- 1-phase: 240 V / 120 V, 60 Hz, 6 kW (Peak: 6 kW)

Generator 4 kW Specifications:

- 1-phase: 240 V / 120 V, 60 Hz, 4 kW
- 1-phase: 230 V / 115 V, 50 Hz, 4 kW

7.14.2 Safety Precautions

WARNING

Do not overload platform.

- Ensure no personnel are beneath platform.
- This factory-installed option is available only on specified models.
- Keep lanyard attached at all times.
- Do not use electrical tools in water.
- Use correct voltage for tool being used.
- Do not overload circuit.

7.14.3 Preparation and Inspection

- Ensure generator is secure.
- Check condition of belt and wiring.

7.14.4 Operation

Start the engine, then turn on the generator.

Refer to the Miller Generator Technical Manual (PN 3121677) for more information.

7.15 SKYSENSE®

WARNING

SkySense is not intended to replace or reduce the need for the operator to be aware of the environment around the machine. Hazards that will cause serious injury or death may not be prevented or reduced by SkySense. The operator must always look in the direction of travel, avoid power lines, avoid obstacles that could strike the machine or persons in the platform, and follow all instructions, decals, and other warnings provided with this machine.

The operator must not rely on SkySense as a substitute for following the instructions and warnings contained in the manuals and placards provided with this machine

SkySense is intended to assist the operator. SkySense may not detect certain objects depending on shape, type of material, or orientation of the object to the sensors. It is the operator's responsibility to be aware of their surroundings at all times.

WARNING

De-rate the platform by 10 lb (4.5 kg) per bar when installed on the platform (20 lb (9 kg) or 30 lb (14 kg) total).

Note: SkySense is not active when operating the machine from the ground controls.

7.15.1 Preparation and Inspection

Pre-Operation Inspection:

1. Inspect each of the SkySense tubes for dents, cracks, or other damage.
2. Inspect each SkySense sensor for any damage to the housing or sensor.

To test the SkySense system:

1. In an area free of obstructions, ensure the machine is on a smooth, firm surface within the limits of the maximum operating slope.
2. From the platform control console, elevate the boom until the bottom of the platform is at least 6 feet off the ground.
3. Continue to elevate the platform.
4. While elevating, hold your hand 6 inches to 12 inches above one of the upward facing sensors. The machine should stop, and the LED corresponding to that sensor (left LED for left sensor bar; right LED for right sensor bar; both LEDs for center sensor bar or overhead sensor) should be red.

5. Ensure the area below the platform is clear of obstructions and lower the platform. The machine should slow down, (SkySense Status LED will blink yellow with increasing frequency) and stop, (SkySense Status LED will be illuminated solid red) when the bottom of the platform is approximately 12 inches from the ground. The alarm should sound if it is not muted (refer to SkySense Alarm).
6. Recycle the footswitch and press the override button on the platform control console.
7. Continue to lower the platform. The machine should move in the elevated drive speed mode (SkySense Status LED will remain red).

Note: The SkySense system will not stop machine operation while in Creep.

7.15.2 Operation

SkySense slows a machine's function to creep speed when it is a certain distance away from an object, known as the "warning zone." If the machine continues to approach the object and moves into the "stop zone," SkySense stops all machine functions.

For proportional functions activated by the joystick, the size of the warning zone varies based on the amount of joystick activation. The stop zone always activates at the same distance from the object regardless of the joystick's position.

If the function has reached the warning zone, normal drive speed will resume when a function is activated in the opposite direction. If the machine has reached the SkySense stop zone, release the function and recycle the footswitch to activate a function in the opposite direction.

SkySense is active during the following functions:

- Lift Up/Down (including jib functions)
- Platform Rotate (including jib rotate)
- Telescope Out
- Swing
- Reverse Drive

Note: During active DOS (Drive Orientation System), SkySense is active when driving in both forward and reverse directions.

There are two LED indicators on the platform control box that signal SkySense activity.

- **No LED:** Normal operation.
- **LED Flashing Yellow:** Machine is in SkySense warning zone and will reduce function speed to creep. Flash frequency correlates to proximity of object.
- **LED Red:** Machine is in SkySense stop zone and all machine functions will cease.
- **LED Flashing Red:** SkySense sensor is obstructed or damaged. Obstructions must be removed and proper function verified. Damaged sensors must be replaced.

7.15.3 SkySense Platform Panel Indicators

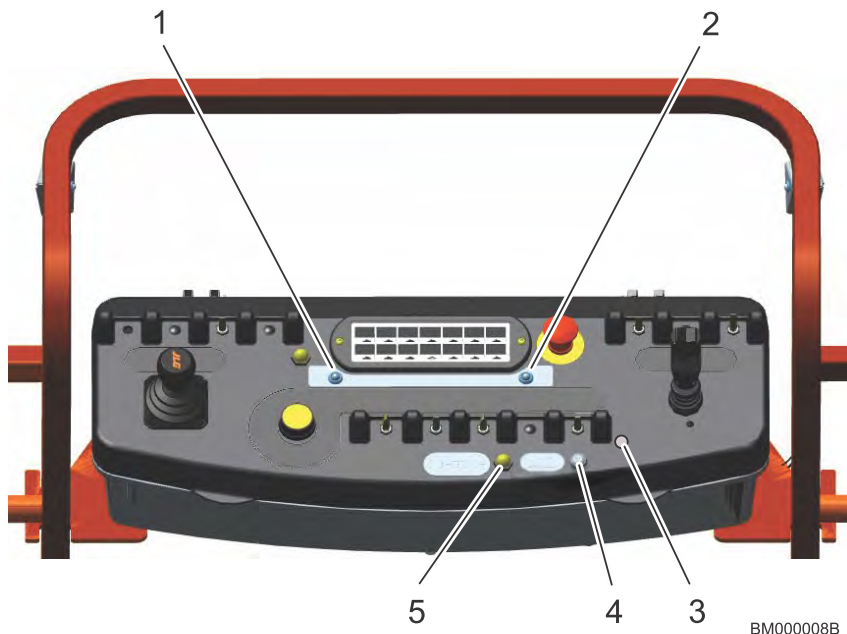

BM000008B

- 1. LED Indicator Light
- 2. LED Indicator Light
- 3. Alternate Mute Speaker Button Position

- 4. Mute Speaker Button
- 5. Override Button

7.15.4 SkySense Alarm

Activation of SkySense is signaled by an audible alarm and the LEDs on the platform console that indicate SkySense activity when reaching the warning or stop zones

In the warning zone, the audible alarm will pulse and increase in frequency as the machine moves closer to the object. In the stop zone, the alarm will sound a continuous tone.

Additionally, when the machine is in the stop zone, the platform control panel audible alarm will sound. The system may be reset by recycling the footswitch.

The audible SkySense alarms can be muted by a button on the platform control console, although LEDs will continue to light. The platform control panel alarm will sound when the machine enters the SkySense stop zone even when muted.

Note: If the machine is equipped with headlights/tail lights or chassis illumination lights options AND the SkySense option, the Mute button will be located in the alternate position (3). *See Figure — SkySense Platform Panel Indicators.*

7.15.5 Override Button

The yellow override button allows operators to bypass normal SkySense operation in order to move closer to an object in the stop zone.

When the operator overrides the SkySense via the override button to get closer to a work surface, the machine will maintain creep speed and flash the appropriate indicator color based on location in either the warning or stop zones.

Note: Override is only required to be engaged if the operator desires to move the platform closer to an object that is in or entering the stop zone.

NOTICE

SkyGuard operation is affected when SkySense is installed on a machine. If SkySense activation occurs prior to SkyGuard activation, SkyGuard will only cut out functions if activated. If SkyGuard activation occurs prior to SkySense activation, SkyGuard will function normally.

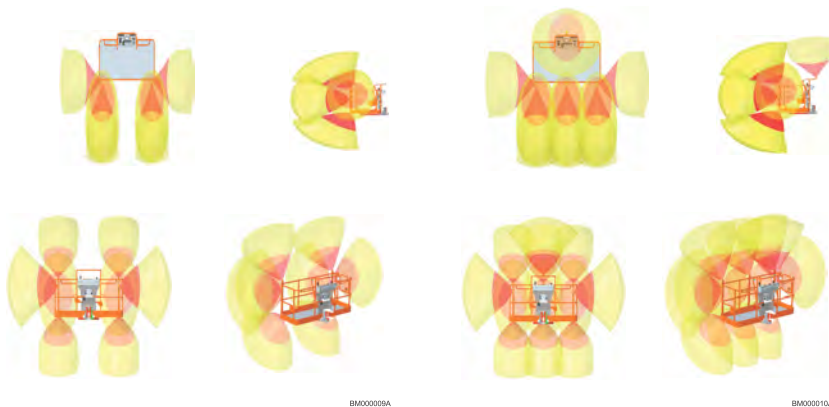
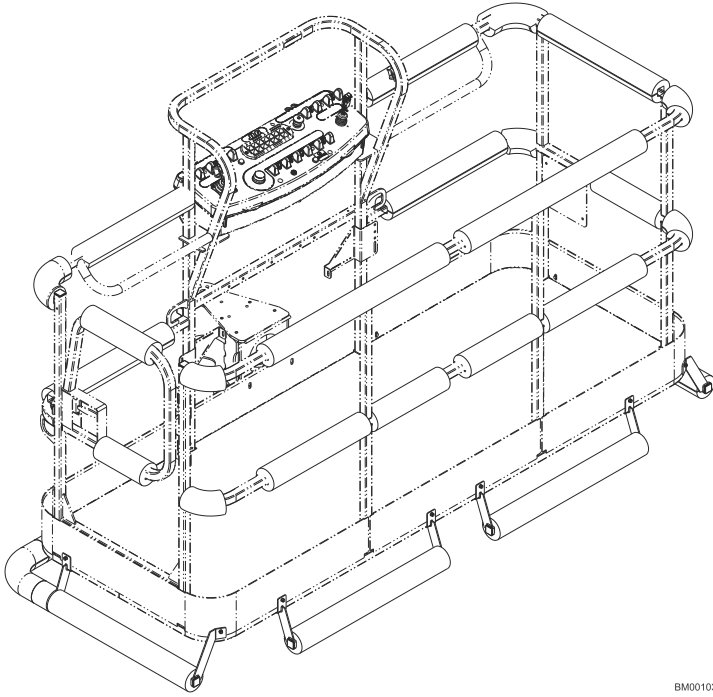

Figure 58. SkySense Coverage Level 1 Areas (2-Bar)

Figure 59. SkySense Coverage Level 2 Areas (3-Bar)

Note: Sensor Cones shown are approximations for reference only.

7.16 SKYSENSE® PLATFORM BUMPER PADDING



BM001038A

Figure 60. Platform Bumper Padding

This accessory outfits machines equipped with the SkySense accessory additional padding for the platform.

7.17 SKYWELDER®

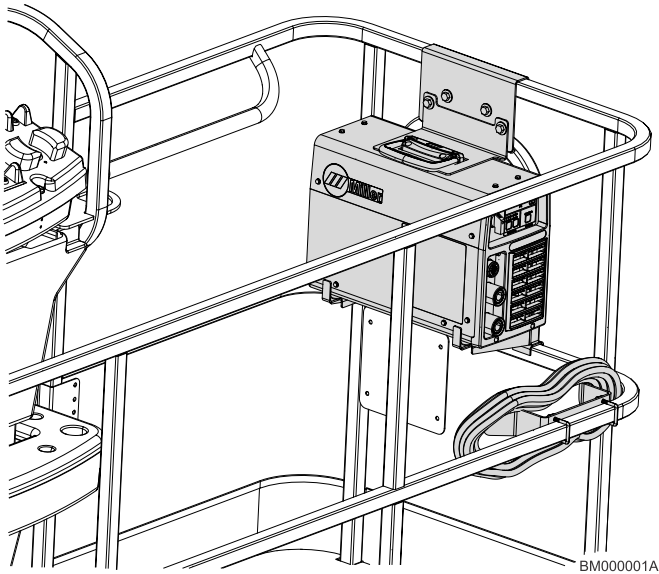

Figure 61. SkyWelder System

SkyWelder is capable of TIG and Stick welding, producing 200 A at 100% duty cycle or 250 A at 50% duty cycle. This accessory receives power from the SkyPower system.

7.17.1 Operation

Start the engine, turn on the generator, then turn on the welder.

See the Miller Welder Owner's Manual (PN 31215476) for more information.

7.17.2 Generator Output

Engine Speed of 1800 rpm +/- 10%.

ANSI Specifications:

- 3-phase: 240 V, 60 Hz, 7.5 kW
- 1-phase: 240 V/120 V, 60 Hz, 6 kW

Table 7. Accessory Ratings Table

Welding Mode	Input Power	Rated Output	Welding Amperage Range	Maximum Open Circuit Voltage	Ampere Input at Rated Load Output (50/60 Hz)					KVA	KW
					208 V	230 V	400 V	460 V	575 V		
Stick (SMAW)	3 — phase	280 A at 31.2 VDC, 35% Duty Cycle	30 — 280 A	103 VDC	29.63	26.65	15.71	13.92	12.08	12	10.2
		200 A at 28 VDC, 100% Duty Cycle			18.86	17.09	10.6	9.37	8.02	8	6.4
	200 A at 28 VDC, 50% Duty Cycle	30 — 200 A	33.7		30.65	17.61	16.18	14.51	8.3	6.6	
	150 A at 26 VDC, 100% Duty Cycle		23.07		20.59	12.97	11.8	11.15	6.4	4.5	
TIG (GTAW)	3 — phase	280 A at 21.2 VDC, 35% Duty Cycle	5 — 280 A	9.5 VDC	20.77	18.85	11.54	10.22	8.95	8.9	7.1
		200 A at 18 VDC, 100% Duty Cycle			12.89	11.74	7.42	6.55	5.49	5.4	4.3
	200 A at 18 VDC, 50% Duty Cycle		22.12		19.71	12.89	11.06	10.61	6.1	4.4	
	150 A at 16 VDC, 100% Duty Cycle	5 — 200 A	14.84		13.38	8.73	8.63	7.72	5.1	2.9	

7.17.3 Welding Accessories

- 12 ft welding leads with clamp and stinger (stored in the platform)
- Fire extinguisher

7.17.4 Safety Precautions

WARNING

Do not overload platform.

WARNING

De-rate the platform by 64 lb (29 kg) when welder is in the platform.

- Check for cracked welds and damage to welder supports.
- Check for proper and secure installation of welder and bracket.
- Ensure no personnel are beneath platform.
- Do not exit platform over rails or stand on rails.
- Use this option only on approved models.
- Keep lanyard attached at all times.
- Ensure correct polarity of leads.
- Wear proper welding apparel.
- Use correct rod size and current settings.
- Do not use electrical cords without ground.
- Do not use electrical tools in water.
- Do not weld to the platform.
- Do not ground through the platform.
- Do not use a high frequency arc starter with TIG welder.

7.17.5 Preparation and Inspection

- Connect ground clamp to metal being welded.
- Ensure there is a good ground connection and observe proper polarity.

7.18 SOFT TOUCH

A padding kit is mounted to the platform rails and to a frame suspended below the platform. Limit switches deactivate platform functions when the padded framework contacts an adjacent structure. A button on the platform console allows override of the system.

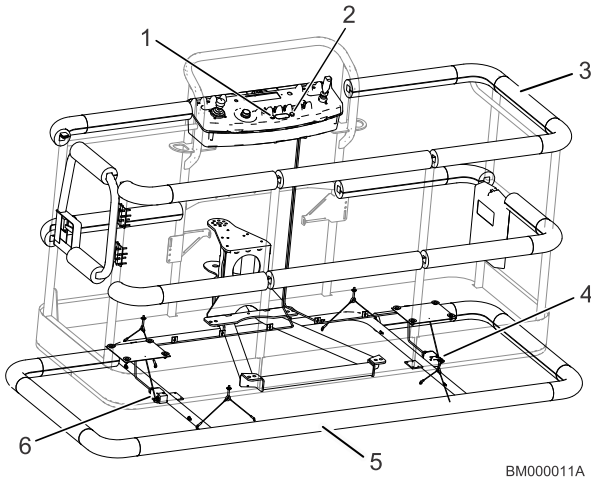

Figure 62. Soft Touch System

1. Override Indicator Light
2. Override Button
3. Rail Bumper
4. Limit Switch
5. Suspended Frame and Rail Bumper
6. Limit Switch

SECTION 8

General Specifications and Operator Maintenance

8.1 GENERAL

This section of the manual provides additional necessary information to the operator for proper operation and maintenance of this machine.

The maintenance portion of this section is intended as information to assist the machine operator to perform daily maintenance tasks only and does not replace the more thorough Preventive Maintenance and Inspection Schedule included in the Service & Maintenance Manual.

8.2 OPERATING SPECIFICATIONS AND PERFORMANCE DATA

8.2.1 Operating Specifications

Capacity - ANSI, CSA, GB, and MOL70	
Unrestricted	500 lb (227 kg)
Restricted	1000 lb (454 kg)
Capacity - CE, UKCA, and Australia	
Unrestricted	500 lb (230 kg)
Restricted	1000 lb (450 kg)
Maximum Operating Slope	4°
Maximum Travel Grade, stowed Position (Gradeability)	40%
Maximum Travel Grade, stowed Position (Side Slope)	4°
Maximum Drive Speed	3.0 mph (4.8 kph)
Gross Machine Weight - Approximate	48000 lb (21772 kg)
Ground Bearing Pressure - Maximum	113 psi (7.94 kg/cm ²)
Maximum Wind Speed	28 mph (12.5 m/s)
Maximum Manual Force	90 lb (400 N)

General Specifications and Operator Maintenance

Maximum System Voltage	12 volts
Maximum Main Relief Hydraulic Pressure	4600 psi (317 Bar)
Ambient (Operating) Temperature	See Figures - Engine Operating Temperature Specifications , through 8-3.

8.2.2 Dimensional Data

Turning Radius (Axles Retracted)	
Outside	22 ft. 6 in. (6.8 m)
Inside	14 ft. 5 in. (4.4 m)
Turning Radius (Axles Extended)	
Inside	8 ft. (2.4 m)
Outside	19 ft. 4 in. (5.9 m)
Machine Height (stowed)	9 ft. 11 in. (3.04 m)
Machine Length	61 ft. 8-5/8 in. (18.81 m)
With Jib Stowed	43 ft. 5/32 in. (13.11 m)
Platform Height	
Unrestricted Capacity	150 ft. 1 in. (45.75 m)
Restricted Capacity	130 ft. 2 in. (39.67 m)
Horizontal Reach from center line of rotation	
Unrestricted Capacity	80 ft. (24.38 m)
Restricted Capacity	64 ft. 11 in. (19.79 m)
Horizontal Reach over end	
Unrestricted Capacity	72 ft. 4 in. (24.38 m)
Restricted Capacity	57 ft. 3 in. (17.45 m)
Horizontal Reach over side	
Unrestricted Capacity	73 ft. 9 in. (22.48 m)
Restricted Capacity	58 ft. 9 in. (17.91 m)
Overall Width	
Axles Retracted	8 ft. 2 in. (2.49 m)
Axles Extended	12 ft. 6 in. (3.8 m)
Wheelbase	12 ft. 6 in. (3.81 m)

Tailswing	5 ft. 5-7/8 in. (1.6 m)
Ground Clearance (Axle)	12 in. (30.4 cm)
Ground Clearance (Chassis)	25.5 in. (64.7 cm)

8.2.3 Capacities

Hydraulic Oil Tank	55 gal. (208 L)
Fuel Tank - Standard	31 gal. (117 L)
Fuel Tank - Optional	52.8 gal. (200 L)
Drive Hub	0.5 quarts (0.5 liters) ± 10%

8.2.4 Tires

Table 8. Size — 445/50D710

Load Range	J
Ply Rating	18
Foam Fill	Polyurethane HD (55 Durometer) Foam
Diameter	46.45 in. (117.9 cm)
Width	18 in. (45.7 cm)
Rim Size	15x28
Tire & Wheel Weight	867 lb (393 kg)
Max Tire Load	28600 lb (12973 kg)

Table 9. Size — 445/65-24

Type	Solid or Solid Non-Marking
Diameter	45.3 in. (115.1 cm)
Width	17.3 in. (43.9 cm)
Rim Size	12.00-24
Tire & Wheel Weight - Solid	960 lb (435.4 kg)

Table 9. Size — 445/65–24 (continued)

Tire & Wheel Weight - Solid Non-Marking	990 lb (449 kg)
Max Tire Load	28600 lb (12973 kg)

8.2.5 Engine Data

Table 10. Deutz TD2011L4 Specifications

Type	Liquid Cooled
Number of Cylinders	4
Bore	3.7 in. (94 mm)
Stroke	4.4 in. (112 mm)
Total Displacement	190 cu. in. (3108 cm ³)
Compression Ratio	17.5:1
Firing Order	1-3-4-2
Output	75 hp (56 kW)
Oil Capacity	
Cooling System	5 Quarts (4.5 L)
w/Filter	11 Quarts (10.5 L)
Total Capacity	16 Quarts (15 L)
Average Fuel Consumption	1.2 gph (4.1 lph)
Idle Engine RPM	1200
Mid Engine RPM	1800
High Engine RPM	2475

Table 11. Deutz TCD2.9L4 Specifications

Type	Liquid Cooled
Number of Cylinders	4
Bore	3.6 in. (92 mm)
Stroke	4.3 in. (110 mm)
Total Displacement	178 cu. in. (2925 cm ³)
Firing Order	1-3-4-2
Output	74.2 hp (55.4 kW)

Table 11. Deutz TCD2.9L4 Specifications (continued)

Oil Capacity	2.4 Gallon (8.9 L)
Coolant Capacity (System)	3.2 Gallon (12.1 L)
Average Fuel Consumption	1.2 gph (4.1 lph)
Min. Low Engine RPM	1200
Mid Engine RPM	1800
Max. High Engine RPM	2500

8.3 HYDRAULIC OIL SPECIFICATIONS

Table 12. Hydraulic Oil SAE Viscosity Grade Operating Temperature Ranges

Hydraulic System Operating Temperature Range	SAE Viscosity Grade
+0° to + 180° F (-18° to +83° C)	10W
+0° to + 210° F (-18° to + 99° C)	10W-20, 10W-30
+50° to + 210° F (+10° to + 99° C)	20W-20

- Note:** Hydraulic oils require anti-wear qualities at least to API Service Classification GL-3 and sufficient chemical stability for mobile hydraulic system service. JLG Industries recommends standard UTTO.
- Note:** Aside from JLG recommendations, it is not advisable to mix oils of different brands or types, as they may not contain the same required additives or be of comparable viscosities. If use of hydraulic oil other than standard UTTO is desired, contact JLG Industries for proper recommendations.
- Note:** Machine operation using non-JLG approved hydraulic fluids or operation outside of the temperature boundaries outlined in the hydraulic fluid operation charts may result in premature wear or damage to components of the hydraulic system.
- Note:** Machines may be equipped with standard UTTO biodegradable and non-toxic hydraulic oil. This is a fully synthetic hydraulic oil that possesses the same anti-wear and rust protection characteristics as mineral oils, but will not adversely affect the ground water or the environment when spilled or leaked in small amounts.
- Note:** When temperatures remain consistently below 20° F (-7° C), JLG Industries recommends the use of a premium "cold weather" hydraulic fluid (Viscosity Gr. 32).

Table 13. Hydraulic Oil Properties and Classifications

Fluid	Properties		Base				Classifications		
	Viscosity at 40° C *	Viscosity Index	Mineral Oils	Vegetable Oils	Synthetic	Synthetic Polyol Esters	Readily Biodegradable**	Virtually Non-toxic †	Fire Resistant ‡
Shell Spirax S4 TXM — Recommended	67	146	X						
Mobilfluid 424 — <i>Optional</i>	60	134	X						
Shell Tellus S2 VX32 — Recommended	32	142	X						
Mobil DTE 10 Excel 32 — <i>Optional</i>	32	164	X						
Shell Tellus S4 VX32 — Recommended	32	296	X						
Univis HVI 26 — <i>Optional</i>	26	376	X						
Shell Naturelle HF-E32 — Recommended	31	192		X			X	X	
Mobil EAL EnviroSyn H32 — <i>Optional</i>	34	146		X			X	X	
Shell Naturelle HF-E46 — Recommended	46	193			X		X	X	
Mobil EAL EnviroSyn H46 — <i>Optional</i>	49	145			X		X	X	

Table 13. Hydraulic Oil Properties and Classifications (continued)

Fluid	Properties		Base				Classifications			
Quintolubric 888-46	48	190				X	X	X	X	
Hydrolube HP-5046D	46	192				X	X	X	X	

* cSt, Typical

** Readily biodegradeable classification indicates one of the following:

CO2 Conversion > 60% per EPA 560/6-82-003

CO2 Conversion > 80% per CEC-L-33-A-93

† Virtually Non-toxic classification indicates a LC50 > 5000 ppm per OECD 203

‡ Fire Resistant classification indicates Factory Mutual Research Corp. (FMRC) Approval

8.4 ENGINE OIL OPERATING TEMPERATURE SPECIFICATIONS

Note: Machine operation using non-JLG approved engine oil or operation outside of the temperature boundaries outlined in the engine oil operation charts may result in premature wear or damage to components of the engine.

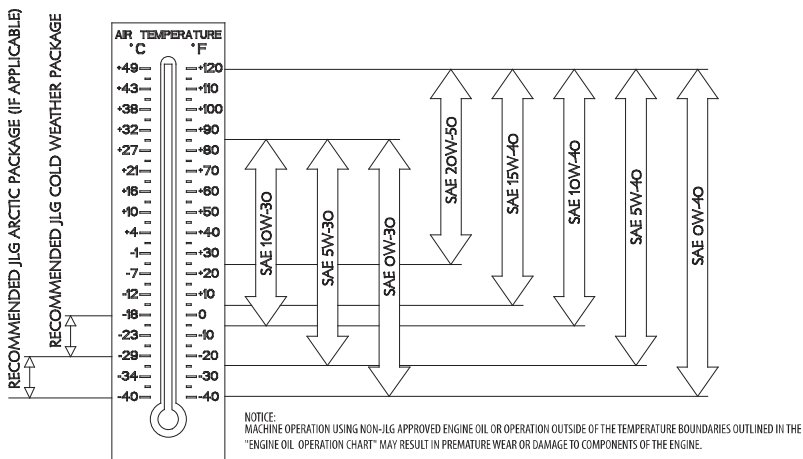

Figure 63. Engine Oil Operating Temperature Specifications - Deutz 2.9L

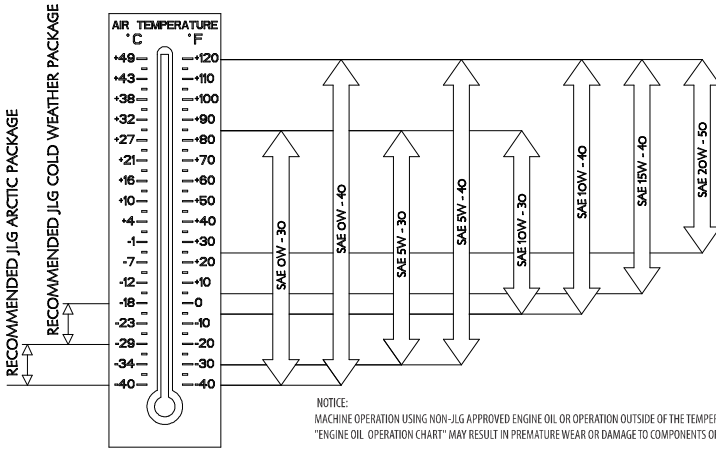

Figure 64. Engine Oil Operating Temperature Specifications - Deutz 2011

1001511946

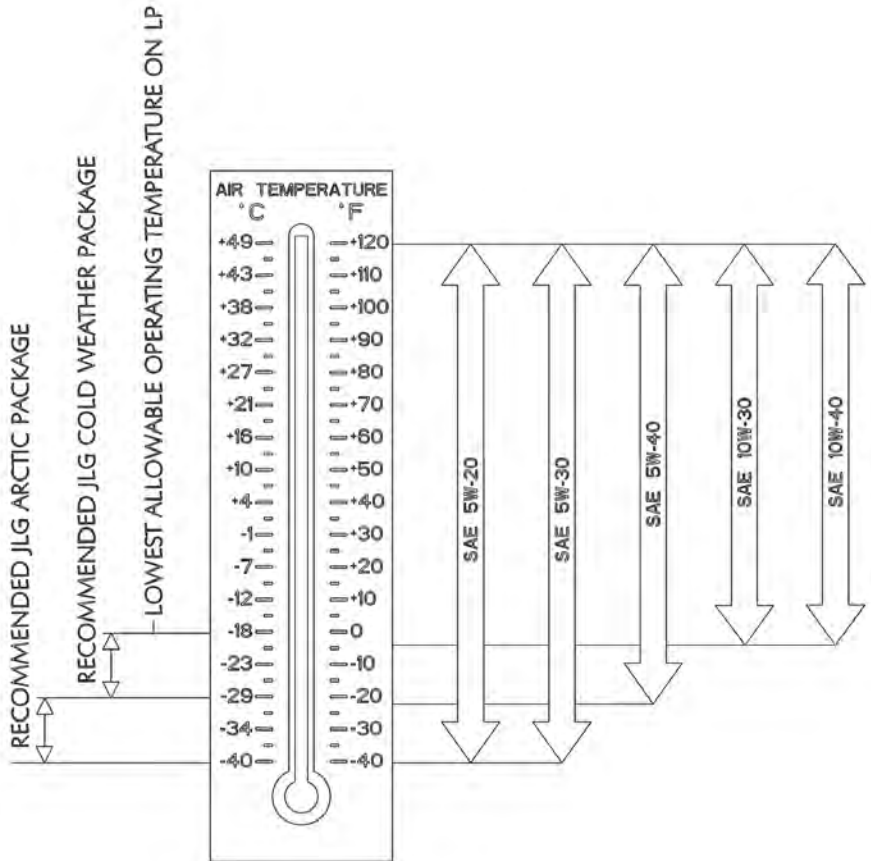
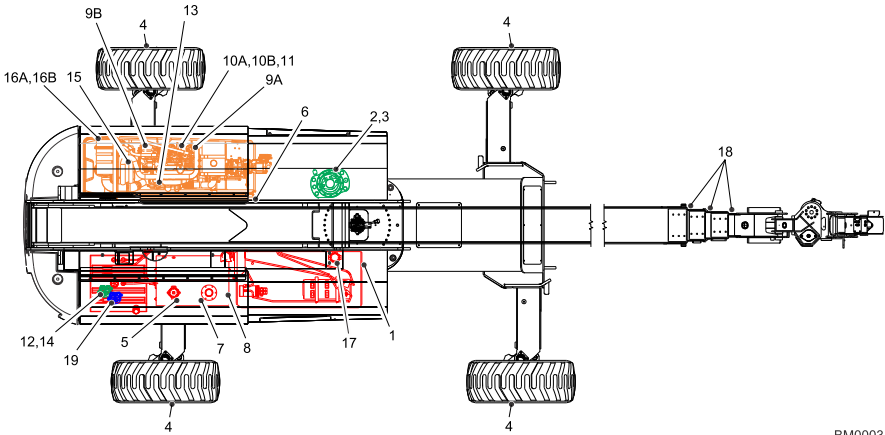

Figure 65. Engine Oil Operating Temperature Specifications - Ford MSG425

8.5 OPERATOR MAINTENANCE AND LUBRICATION DIAGRAMS



BM00034

8.6 OPERATOR MAINTENANCE

Note: The following numbers correspond to those in *Figure — Operator Maintenance and Lubrication Diagram*.

Table 14. Lubrication Specifications.

KEY	SPECIFICATIONS
MPG	Multipurpose Grease having a minimum dripping point of 350° F (177° C). Excellent water resistance and adhesive qualities, and being of extreme pressure type. (Timken OK 40 pounds minimum.)
EPGL	Extreme Pressure Gear Lube (oil) meeting API service classification GL-5 or MIL-Spec MIL-L-2105
HO	Hydraulic Oil. API service classification GL-3, e.g. Standard UTTO
EO	Engine (crankcase) Oil. Gas - API SF, SH, SG class, MIL-L-2104. Diesel - API CC/CD class, MIL-L-2104B/MIL-L-2104C

Table 14. Lubrication Specifications. (continued)

KEY	SPECIFICATIONS
Super Lube®	Synthetic-Based Oil, Non-Flammable. Withstands temperatures within -45° to 450°F (-43° to 232° C). JLG P/N 3020042.

NOTICE

Lubrication intervals are based on machine operation under normal conditions. For machines used in multi-shift operations and/or exposed to hostile environments or conditions, lubrication frequencies must be increased accordingly.

1. Swing Bearing - Remote Lube
 Lube Point(s) - 2 Grease Fitting
 Capacity - A/R
 Lube - MPG
 Interval - Every 3 months or 150 hours of operation.



2. Swing Gearbox

Lube Point(s) - Fill Plug

Capacity - 79 ounces (2.3 L)

Lube - GL-5

Interval - Check level every 150 hrs/Change every 1200 hours of operation. Fill to cover ring gear.

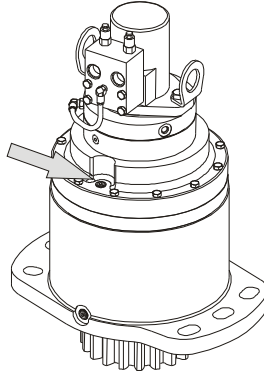

3. Swing Brake

Lube Point(s) - Fill Plug

Capacity - 2.7 ounces (80 ml)

Lube - DTE24

Interval - Check level every 150 hrs/Change every 1200 hours of operation. Fill to cover ring gear.

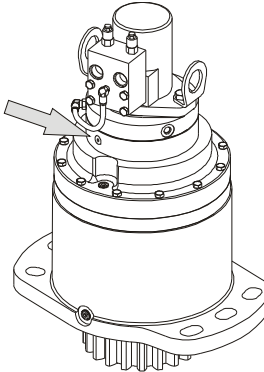

4. B: Wheel Drive Hub

Lube Point(s) - Level/Fill Plug

Capacity - 0.5 quarts (0.5 liters) \pm 10%

Lube - EPGL

Interval - Check level every 150 hrs/Change every 1200 hours of operation. Fill to cover ring gear.

Comments - Place Fill port at 12 o'clock position and Check port at 3 o'clock position. Pour lubricant into fill port until it just starts to flow out of check port.



5. Hydraulic Return Filter

Lube Point(s) - Replaceable Element

Interval - Change after first 50 hours and every 300 hours thereafter or as indicated by condition indicator.

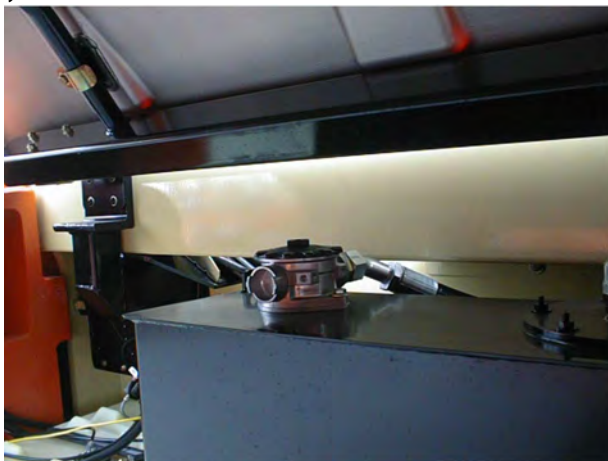

General Specifications and Operator Maintenance

6. Hydraulic Charge Filter

Lube Point(s) - Replaceable Element

Interval - Change after first 50 hours and every 300 hours thereafter or as indicated by condition indicator.



7. Hydraulic Oil

Lube Point(s) - Fill Cap

Capacity - Standard 31 gallons (117 liters)

Optional 52.8 gallons (200 liters)

Lube - HO

Interval - Check level daily. Change every 2 years or 1200 hours of operation.

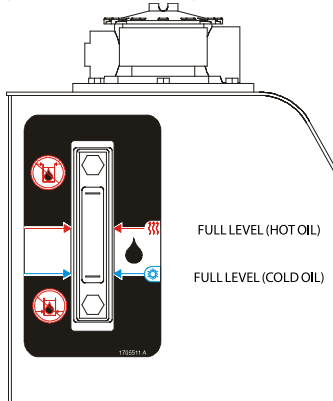

8. Suction Strainers (In Tank)
Lube Point(s) - 2
Interval - Every 2 years or 1200 hours of operation.
Remove and clean at time of hydraulic oil change.

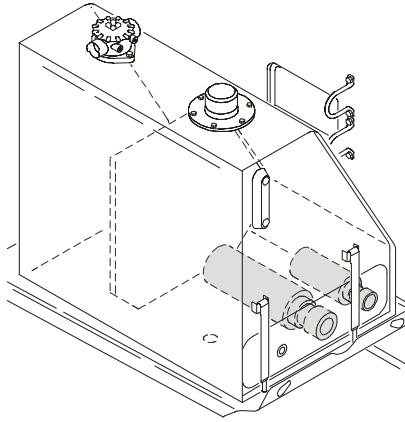

General Specifications and Operator Maintenance

9. A. Oil Change w/Filter - Deutz TD2011

Lube Point(s) - Fill Cap/Spin-on Element

Capacity -

5 Quarts (4.5 L) Cooling System

11 Quarts (10.5 L) w/Filter

16 Quarts (15 L) Total Capacity

Lube - EO

Interval - Check level daily; change every 500 hours or six months, whichever comes first. Adjust final oil level by mark on dipstick.



B. Oil Change w/Filter - Deutz TCD2.9

Lube Point(s) - Fill Cap/Spin-on Element

Capacity - 2.4 Gallon (8.9 L)

Lube - EO

Interval - Check level daily; change every 500 hours or six months, whichever comes first. Adjust final oil level by mark on dipstick.



10. A. Fuel Filter - Deutz TD2011
Lube Point(s) - Replaceable Element
Interval - Every year or 600 hours of operation.



- B. Fuel Filter - Deutz TCD2.9
Lube Point(s) - Replaceable Element
Interval - Every year or 600 hours of operation.



11. Fuel Strainer TD2011
Lube Point(s) - Replaceable Element
Interval - Every year or 600 hours of operation.

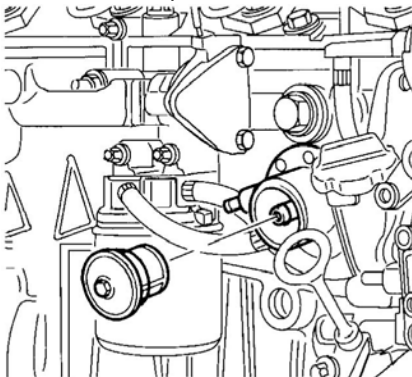

General Specifications and Operator Maintenance

12. Fuel Pre-Filter TCD2.9
Lube Point(s) - Replaceable Element
Interval - Drain water daily; Change every year or 600 hours of operation.

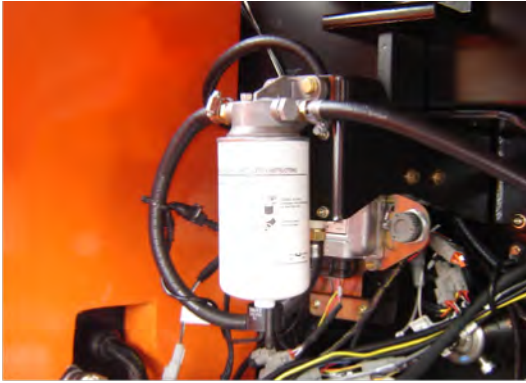

13. Radiator Coolant TCD2.9
Lube Point(s) - Fill Cap
Capacity - 3.2Gallon (12.1 L)
Lube - Anti-Freeze
Interval - Check level daily; change every 1000 hours or 2 years, whichever comes first.



14. A. Air Filter - Deutz TD2011

Lube Point(s) - Replaceable Element

Interval - Every 6 months or 300 hours of operation or as indicated by the condition indicator.



B. Air Filter - Deutz TCD2.9

Lube Point(s) - Replaceable Element

Interval - Every 6 months or 300 hours of operation or as indicated by the condition indicator.

Comments - Check Dust Valve daily.

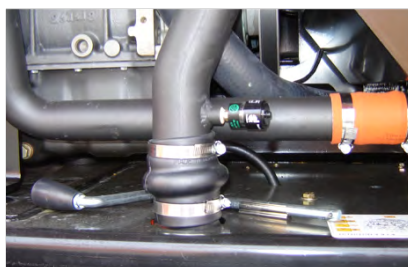

15. Platform Filter
Lube Point(s) - Replaceable Element
Interval - Change after first 50 hours and then every year or 600 hours of operation thereafter.



16. Boom
Lube Point(s) - Apply to wear pad contact paths
Lube - Super Lube®
Interval - As needed. Refer to the Service Manual for detailed procedures.

17. Optional Fuel Filter/Water Separator
Lube Point(s) - Replaceable Element
Interval - Drain water daily; Change every year or 600 hours of operation.

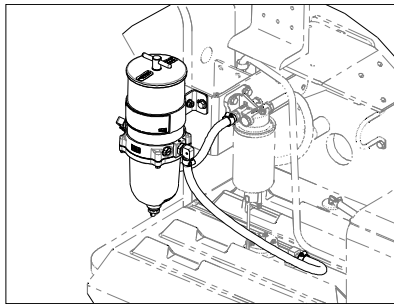
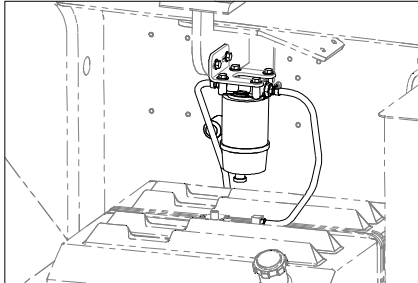

8.7 TIRES AND WHEELS

8.7.1 Tire Damage

For polyurethane foam filled tires, JLG Industries, Inc. recommends that when any of the following are discovered, measures must be taken to remove the JLG product from service immediately and arrangements must be made for replacement of the tire or tire assembly.

- a smooth, even cut through the cord plies which exceeds 3 inches (7.5 cm) in total length
- any tears or rips (ragged edges) in the cord plies which exceeds 1 inch (2.5 cm) in any direction
- any punctures which exceed 1 inch in diameter
- any damage to the bead area cords of the tire

If a tire is damaged but is within the above noted criteria, the tire must be inspected on a daily basis to insure the damage has not propagated beyond the allowable criteria.

8.7.2 Tire Replacement

JLG recommends a replacement tire be the same size, ply and brand as originally installed on the machine. Please refer to the JLG Parts Manual for the part number of the approved tires for a particular machine model. If not using a JLG approved replacement tire, we recommend that replacement tires have the following characteristics:

- Equal or greater ply/load rating and size of original
- Tire tread contact width equal or greater than original
- Wheel diameter, width, and offset dimensions equal to the original
- Approved for the application by the tire manufacturer (including inflation pressure and maximum tire load)

Unless specifically approved by JLG Industries Inc. do not replace a foam filled or ballast filled tire assembly with a pneumatic tire. When selecting and installing a replacement tire, ensure that all tires are inflated to the pressure recommended by JLG. Due to size variations between tire brands, both tires on the same axle should be the same.

8.7.3 Wheel and Tire Replacement

The rims installed on each product model have been designed for stability requirements which consist of track width, tire pressure, and load capacity. Size changes such as rim width, center piece location, larger or smaller diameter, etc., without written factory recommendations, may result in an unsafe condition regarding stability.

8.7.4 Wheel Installation

It is extremely important to apply and maintain proper wheel mounting torque.

⚠ WARNING

Wheel nuts must be installed and maintained at the proper torque to prevent loose wheels, broken studs, and possible dangerous separation of wheel from the axle. Be sure to use only the nuts matched to the cone angle of the wheel.

Tighten the lug nuts to the proper torque to prevent wheels from coming loose. Use a torque wrench to tighten the fasteners. If you do not have a torque wrench, tighten the fasteners with a lug wrench, then immediately have a service garage or dealer tighten the lug nuts to the proper torque. Over-tightening will result in breaking the studs or permanently deforming the mounting stud holes in the wheels. The proper procedure for attaching wheels is as follows:

1. Start all nuts by hand to prevent cross threading. **DO NOT** use a lubricant on threads or nuts.
2. Tighten nuts in the following sequence:

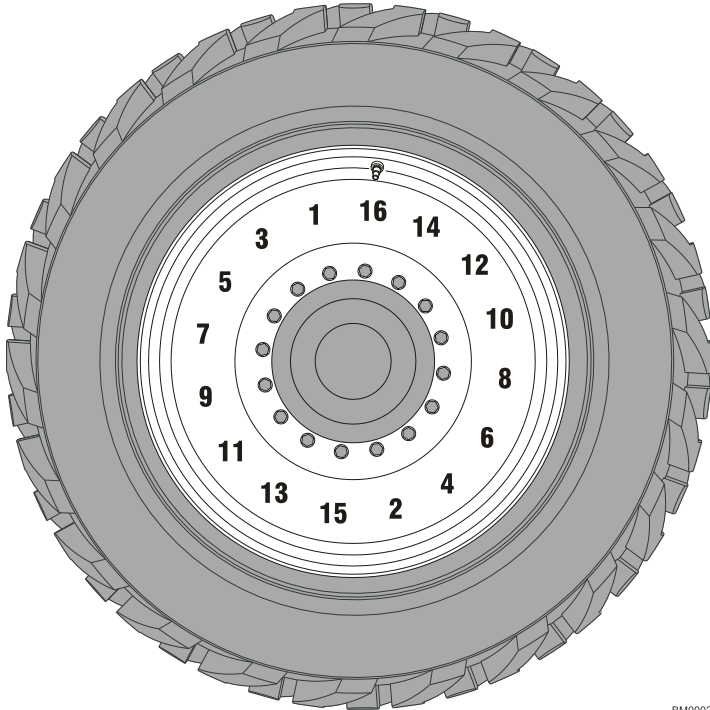

BM00025

3. The tightening of the nuts should be done in stages. Following the recommended sequence, tighten nuts per wheel torque chart.

Table 15. Wheel Torque Chart

TORQUE SEQUENCE		
1st Stage	2nd Stage	3rd Stage
45 ft. lbs. (60 Nm)	100 ft. lbs. (140 Nm)	180 ft. lbs. (252 Nm)

4. Wheel nuts should be torqued before first road use and after each wheel removal. Check and torque every 3 months or 150 hours of operation.

8.8 SUPPLEMENTAL INFORMATION ONLY APPLICABLE TO CE/UKCA MACHINES

The following information is provided in accordance with the requirements of the European Machinery Directive 2006/42/EC or Supply of Machinery (Safety) Regulations 2008 No. 1597.

The A-Weighted emission sound pressure level at the work platform is less than 70 dB (A).

The guaranteed Sound Power Level (LWA) per European Directive 2000/14/EC (Noise Emission in the Environment by Equipment for Use Outdoors) or Noise Emission in the Environment by Equipment for use Outdoors Regulations 2001 No. 1701 based on test methods in accordance with Annex III, Part B, Method 1 and 0 of the directive, is 104 dB (A) for machines equipped with Stage IIIA engines and 108 dB (A) for machines equipped with Stage IIIB engines.

The vibration total value to which the hand-arm system is subjected does not exceed 2,5 m/s². The highest root mean square value of weighted acceleration to which the whole body is subjected does not exceed 0,5 m/s².

8.9 EC DECLARATION OF CONFORMITY

Manufacturer

JLG Industries, Inc.

Address

1 JLG Drive
McConnellsburg, PA 17233 USA

Technical File

JLG EMEA B.V.
Polaris avenue 63,
2132 JH Hoofddorp
The Netherlands

Contact/Position

Senior Manager — Product Safety & Reliability

Date/Place

Hoofddorp, Netherlands

Machine Type

Mobile Elevating Work Platform

Model Type

1500SJ

EC-Number

2842

Certificate Number

KCEC4436

Notified Body

Kuiper Certificering b.v.

Address

Van Slingelandtstraat 75, 7331 NM
Apeldoorn, The Netherlands

Reference Standards

- EN 55011:2009/A1:2010
- EN 61000-6-2:2005
- EN 60204-1:2018
- EN 280:2013+ A1:2015
- EN ISO 12100:2010

JLG Industries, Inc. hereby declares that the above mentioned machine conforms with the requirements of:

- 2006/42/EC — Machinery Directive
- 2014/30/EU — EMC Directive
- 2014/53/EU — RED Directive (If fitted with optional equipment)
- 2000/14/EC — Outdoor Noise Directive

Note: This declaration conforms with the requirements of annex II-A of the council directive 2006/42/EC. Any modification of the above described machine violates the validity of this declaration.

8.10 UKCA DECLARATION OF CONFORMITY

Manufacturer

JLG Industries, Inc.

Address

1 JLG Drive
McConnellsburg, PA 17233 USA

Technical File

JLG Industries UK Ltd
Braunstone Frith Industrial Estate
Unit 3 Sunningdale Road
Leicester, LE3 1UX
United Kingdom

Contact/Position

Director of Engineering — Europe

Date/Place

Leicester, United Kingdom

Machine Type

Mobile Elevating Work Platform

Model Type

1500SJ

AB-Number

0463

Certificate Number

AVUK4436

Notified Body

Amtri Veritas

Address

Pierce Street, Macclesfield, SK11 6ER, England

Reference Standards

- EN 55011:2009/A1:2010
- EN 61000-6-2:2005
- EN 60204-1:2018
- EN 280:2013+ A1:2015
- EN ISO 12100:2010

JLG Industries, Inc. hereby declares that the above mentioned machine conforms with the requirements of:

- 2008 No. 1597 - Supply of Machinery (Safety) Regulations 2008
- 2016 No. 1091 - Electromagnetic Compatibility Regulations 2016
- 2017 No. 1206 - Radio Equipment Regulations 2017 (if fitted with optional equipment)
- 2001 No. 1701 - Noise Emission in the Environment by Equipment for use Outdoors Regulations 2001

Note: This declaration conforms with the requirements of annex II-A of the Regulations 2008 No. 1597. Any modification of the above described machine violates the validity of this declaration.



Corporate Office
JLG Industries, Inc.
1 JLG Drive
McConnellsburg, PA 17233-9533 USA
☎ (717) 485-5161 (Corporate)
☎ (877) 554-5438 (Customer Support)
☎ (717) 485-6417

Visit our website for JLG Worldwide Locations.
www.jlg.com



OSHKOSH™